

**LOCATION MAP**  
NO SCALE

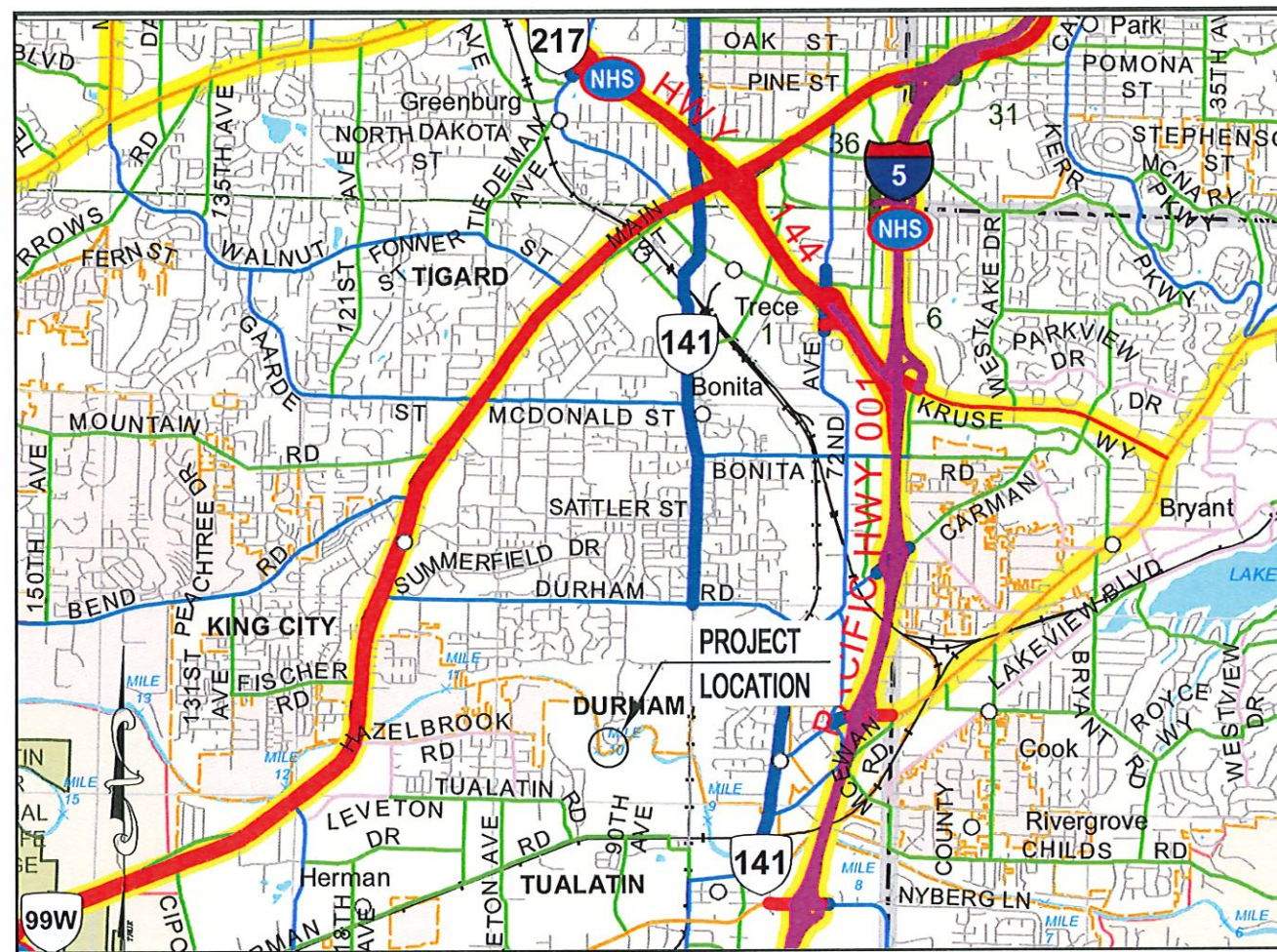

**VICINITY MAP**  
0 1 2 3 4  
SCALE IN MILES

**DRAWING INDEX**

- |   |   |
|---|---|
| 01 - TITLE SHEET                                  | 11 - PILE HOOP MOUNTING PLATE & DETAILS   |
| 02 - BOARDING DOCK LAYOUT PLAN                    | 12 - EXTERNAL PILE HOOP DETAILS           |
| 03 - ALUMINUM BOARDING DOCK VIEWS (TYPE "A" DOCK) | 13 - HINGE BARREL ASSEMBLY DETAILS        |
| 04 - DOCK W/ EXTERNAL PILE HOOP (LEFT SIDE)       | 14 - LAST DOCK DETAILS                    |
| 05 - ALUMINUM BOARDING DOCK SECTIONS              | 15 - BULLRAIL DETAILS                     |
| 06 - SHELL DETAILS (TYPE "A" DOCK)                | 16 - STRUCTURAL DETAILS                   |
| 07 - PILE HOOP STIFFENER LAYOUT & DETAILS         | 17 - ABUTMENT HINGE DETAILS               |
| 08 - STRUCTURAL LAYOUT                            | 18 - FIBERGLASS DECK PANEL DETAILS        |
| 09 - FOAM, CONCRETE, WALE DETAILS                 | 19 - DOGLEG DOCK (TYPE "A")               |
| 10 - TOPSIDE LAYOUT (TYPE "A" DOCK)               | 20 - HINGE BARREL STIFFENER (DOGLEG DOCK) |

GEOGRAPHIC LOCATION	
TOWNSHIP:	02 SOUTH
RANGE:	01 WEST
SECTION:	14
TAX LOT:	100
COUNTY:	WASHINGTON
LATITUDE:	45.39389 NORTH
LONGITUDE:	122.77198 WEST
USGS QUAD MAP:	BEAVERTON

# ALUMINUM BOARDING DOCKS - FABRICATE & DELIVER

## COOK PARK RAMP, TUALATIN RIVER - MILE 9.8

### CITY OF TIGARD



FINAL CHECK SIGNATURE  
*Allen Chiou*

DESIGNER: ALLEN C.  
DRAFTER: ALLEN C.  
DATE: 8/15/24

SHEET STATUS  
**FINAL**  
AS ADVERTISED



PROJECT LOCATION, WATERBODY & FACILITY OWNER:  
COOK PARK RAMP, TUALATIN RIVER - MILE 9.8  
CITY OF TIGARD

SHEET DESCRIPTION:  
TITLE SHEET

SHEET NUMBER  
**01**

SHEET 01 OF 20  
DRAWING NO.  
3403 - 1730 - 01



**DOCK 1 NOTES:**  
 1. TYPE "A" DOCK WITH SHORE-END MODIFICATIONS. SEE SHEET 17.  
 2. ON LEFT SIDE (WHEN FACING DOWNHILL), NO WALES, WALE BLOCKS, OR RUBSTRIPS. KEEP PILE HOOP STIFFENER & WALE SUPPORT.  
 3. ON LEFT SIDE (WHEN FACING DOWNHILL), INSTALL PILE HOOP MOUNTING PLATE WITHOUT RUB BLOCKS. SEE SHEET 04 FOR PILE HOOP MOUNTING LOCATION. PILE HOOP MOUNTING PLATE IS FOR FUTURE PILE INSTALLATION.

**DOCK 2 & 3 NOTES:**  
 1. STANDARD TYPE "A" DOCK. SEE SHEET 03.

**DOCK 4 NOTES:**  
 1. TYPE "A" DOGLEG DOCK WITH EXTERNAL PILE HOOP & SIDE HINGE ASSEMBLY. SEE SHEET 19.  
 2. SEE SHEET 04 FOR PILE HOOP MOUNTING LOCATION.

**DOCK 5 NOTES:**  
 1. TYPE "A" DOCK WITH EXTERNAL PILE HOOP, OFFSHORE-END MODIFICATIONS, & MODIFIED BULLRAILS.  
 2. SEE SHEET 04 FOR PILE HOOP MOUNTING LOCATION.

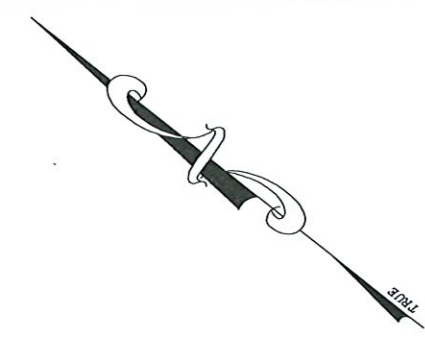
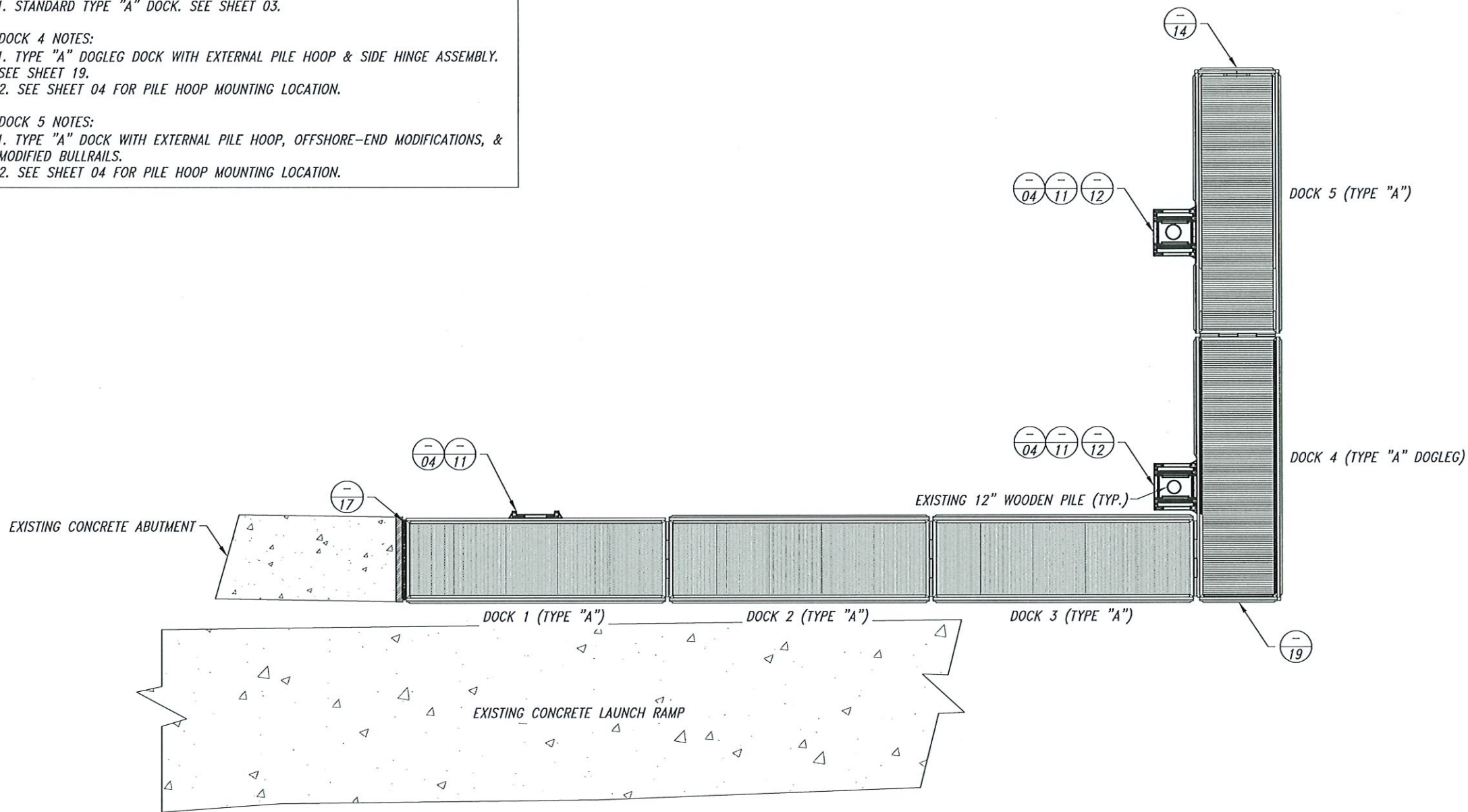

TUALATIN RIVER - MILE 9.8

**BOARDING DOCK LAYOUT PLAN**



DESIGN ENGINEER

REGISTERED PROFESSIONAL ENGINEER  
 103987PE

*Allen H. Chiou*

OREGON  
 NOV. 14, 2023

ALLEN H. CHIOU

EXPIRES: 12-31-25

FINAL CHECK SIGNATURE  
*Allen H. Chiou*

DESIGNER: ALLEN C.  
 DRAFTER: ALLEN C.  
 DATE: 8/15/24

SHEET STATUS  
**FINAL**  
 AS ADVERTISED



PROJECT LOCATION, WATERBODY & FACILITY OWNER:  
**COOK PARK RAMP, TUALATIN RIVER - MILE 9.8**  
**CITY OF TIGARD**

SHEET DESCRIPTION:  
**BOARDING DOCK LAYOUT PLAN**

SHEET NUMBER  
**02**

SHEET 02 OF 20  
 DRAWING NO.  
 3403 - 1730 - 02





FINAL CHECK SIGNATURE  
*Allen Chiu*

DESIGNER: ALLEN C.  
 DRAFTER: ALLEN C.  
 DATE: 8/15/24

SHEET STATUS  
**FINAL**  
 AS ADVERTISED



PROJECT LOCATION, WATERBODY & FACILITY OWNER  
 COOK PARK RAMP, TUALATIN RIVER - MILE 9.8  
 CITY OF TIGARD  
 SHEET DESCRIPTION:  
**ALUMINUM BOARDING DOCK VIEWS (TYPE "A" DOCK)**  
 SHEET NUMBER  
**03**  
 SHEET 03 OF 20  
 DRAWING NO.  
 3403 - 1730 - 03

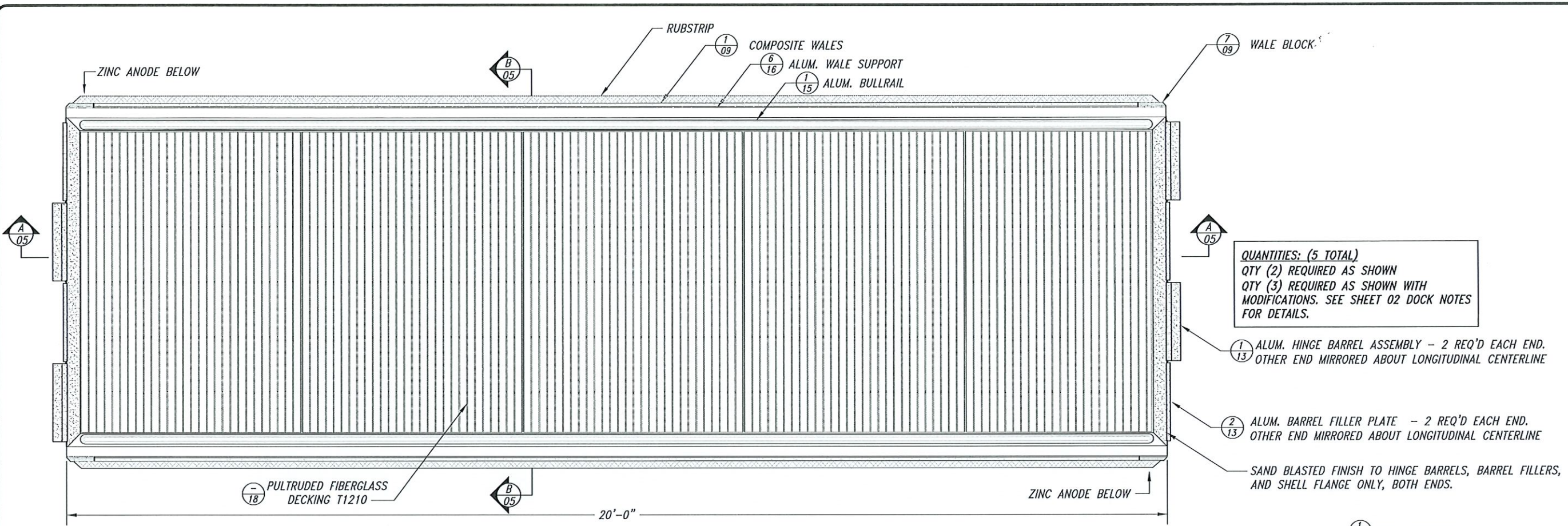

QUANTITIES: (5 TOTAL)  
 QTY (2) REQUIRED AS SHOWN  
 QTY (3) REQUIRED AS SHOWN WITH  
 MODIFICATIONS. SEE SHEET 02 DOCK NOTES  
 FOR DETAILS.

- ① ALUM. HINGE BARREL ASSEMBLY - 2 REQ'D EACH END. OTHER END MIRRORED ABOUT LONGITUDINAL CENTERLINE
- ② ALUM. BARREL FILLER PLATE - 2 REQ'D EACH END. OTHER END MIRRORED ABOUT LONGITUDINAL CENTERLINE
- SAND BLASTED FINISH TO HINGE BARRELS, BARREL FILLERS, AND SHELL FLANGE ONLY, BOTH ENDS.

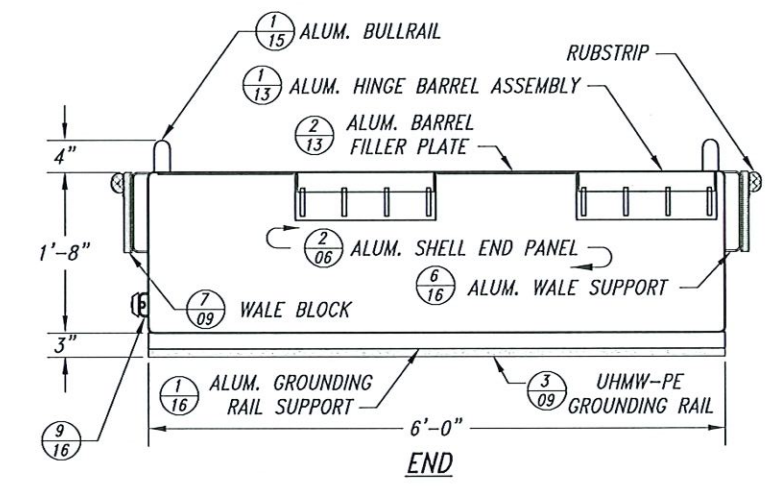
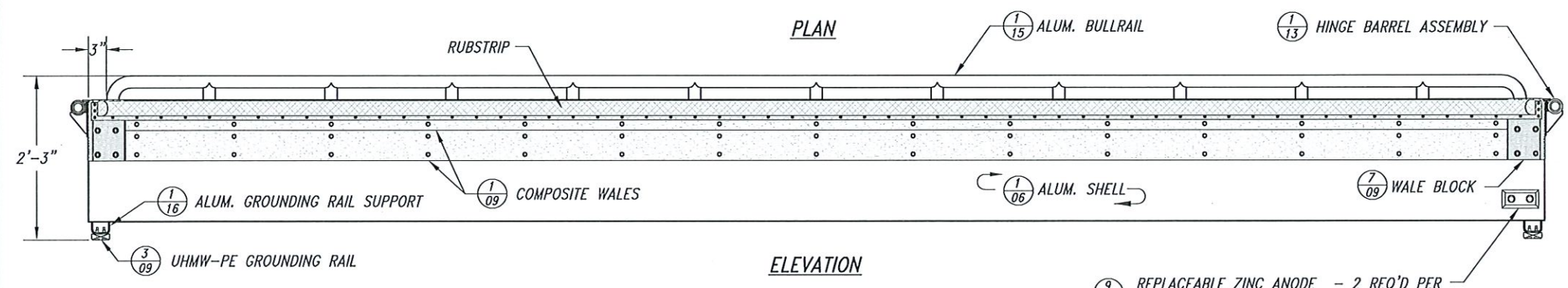

- ⑨ REPLACEABLE ZINC ANODE - 2 REQ'D PER DOCK LOCATED AT OPPOSING CORNERS

ALUMINUM BOARDING DOCK VIEWS (TYPE "A" DOCK)

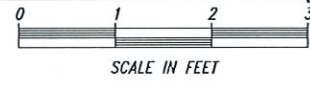

NOTES:  
 1. ALL PLATE, FLAT BAR, AND FORMED SHAPES SHALL BE 5086 ALUMINUM ALLOY PER SPECIFICATIONS.  
 2. ALL ROUND TUBE SHALL BE 6061 ALUMINUM ALLOY PER SPECIFICATIONS.

ANTICIPATED ASSEMBLY SEQUENCE:

1. FABRICATE SHELL
2. INSTALL SHELL END PANELS
3. INSTALL GROUNDING RAIL SUPPORTS & GROUNDING RAILS
4. INSTALL BULKHEADS
5. INSTALL BOTTOM STIFFENERS
6. INSTALL END STIFFENERS
7. INSTALL BULLRAIL GUSSETS
8. INSTALL WALE SUPPORTS & ANODE BRACKETS
9. INSTALL HINGE BARREL ASSEMBLIES & FILLER PLATES
10. INSTALL BULLRAILS
11. SANDBLAST HINGE BARRELS AND ADJACENT SHELL FLANGE
12. APPLY BARRIER COATING PRIOR TO PLACING CONCRETE
13. INSTALL CONCRETE BALLAST
14. INSTALL FOAM FLOATATION
15. INSTALL & SECURE TOP COVERS
16. INSTALL & SECURE TOP COVER SPACERS
17. INSTALL DECK SUPPORTS
18. INSTALL DECKING
19. INSTALL WALES
20. INSTALL RUBSTRIPS
21. INSTALL ZINC ANODES

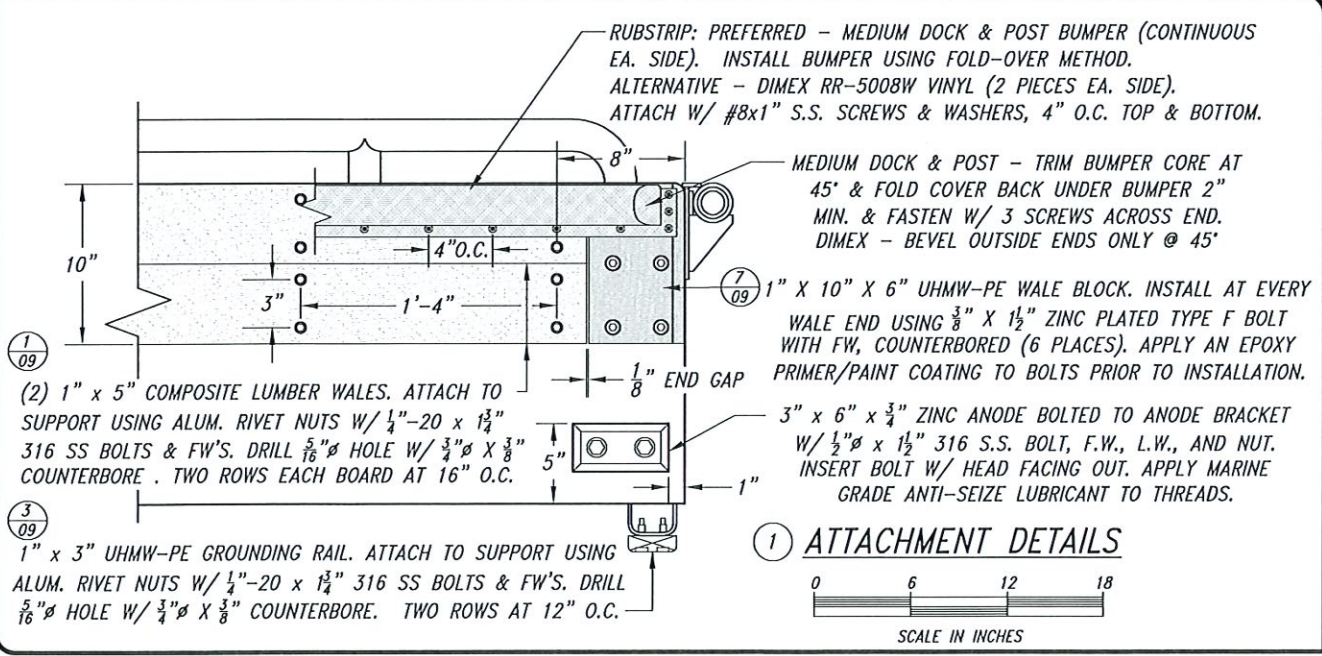

① ATTACHMENT DETAILS



RUBSTRIP: PREFERRED - MEDIUM DOCK & POST BUMPER (CONTINUOUS EA. SIDE). INSTALL BUMPER USING FOLD-OVER METHOD. ALTERNATIVE - DIMEX RR-500BW VINYL (2 PIECES EA. SIDE). ATTACH W/ #8x1" S.S. SCREWS & WASHERS, 4" O.C. TOP & BOTTOM.

MEDIUM DOCK & POST - TRIM BUMPER CORE AT 45° & FOLD COVER BACK UNDER BUMPER 2" MIN. & FASTEN W/ 3 SCREWS ACROSS END. DIMEX - BEVEL OUTSIDE ENDS ONLY @ 45°

⑦ 1" X 10" X 6" UHMW-PE WALE BLOCK. INSTALL AT EVERY WALE END USING 3/8" X 1 1/2" ZINC PLATED TYPE F BOLT WITH FW, COUNTERBORED (6 PLACES). APPLY AN EPOXY PRIMER/PAIN COATING TO BOLTS PRIOR TO INSTALLATION.

② 1" X 5" COMPOSITE LUMBER WALES. ATTACH TO SUPPORT USING ALUM. RIVET NUTS W/ 1/4"-20 X 1 1/4" 316 SS BOLTS & FW'S. DRILL 5/16" Ø HOLE W/ 3/4" X 3/8" COUNTERBORE. TWO ROWS EACH BOARD AT 16" O.C.

③ 1" X 3" UHMW-PE GROUNDING RAIL. ATTACH TO SUPPORT USING ALUM. RIVET NUTS W/ 1/4"-20 X 1 1/4" 316 SS BOLTS & FW'S. DRILL 5/16" Ø HOLE W/ 3/4" X 3/8" COUNTERBORE. TWO ROWS AT 12" O.C.



PILE HOOP DETAIL TABLE			
DOCK No.	MODIFICATIONS FROM STANDARD	D1	D2
DOCK 1	SEE SHEET 02	7'-11"	7'-11"
DOCK 4	SEE SHEETS 02, 19	6'-5"	9'-5"
DOCK 5	SEE SHEET 02	5'-7 $\frac{1}{8}$ "	10'-2 $\frac{1}{8}$ "

D1 = DISTANCE FROM THE SHORE END OF THE DOCK  
D2 = DISTANCE FROM THE OFFSHORE END OF THE DOCK.  
D1 & D2 ARE MEASURED FROM THE END OF THE DOCK SHELL TO THE LEADING EDGE OF THE HOOP MOUNTING PLATE.

REFERENCE STANDARD TYPE "A" ALUMINUM DOCK DETAILS FOR CONSTRUCTION, MODIFY AS SHOWN ON THIS PAGE FOR INSTALLATION OF EXTERNAL PILE HOOP MOUNTING PLATE, LEFT SIDE.



FINAL CHECK SIGNATURE  
*Allen Chou*  
DESIGNER: ALLEN C.  
DRAFTER: ALLEN C.  
DATE: 8/15/24

SHEET STATUS  
**FINAL**  
AS ADVERTISED



PROJECT LOCATION, WATERBODY & FACILITY OWNER  
**COOK PARK RAMP, TUALATIN RIVER - MILE 9.8**  
**CITY OF TIGARD**  
SHEET DESCRIPTION:  
**DOCK W/ EXTERNAL PILE HOOP (LEFT SIDE)**

SHEET NUMBER  
**04**  
SHEET 04 OF 20  
DRAWING NO.  
3403-1730-04

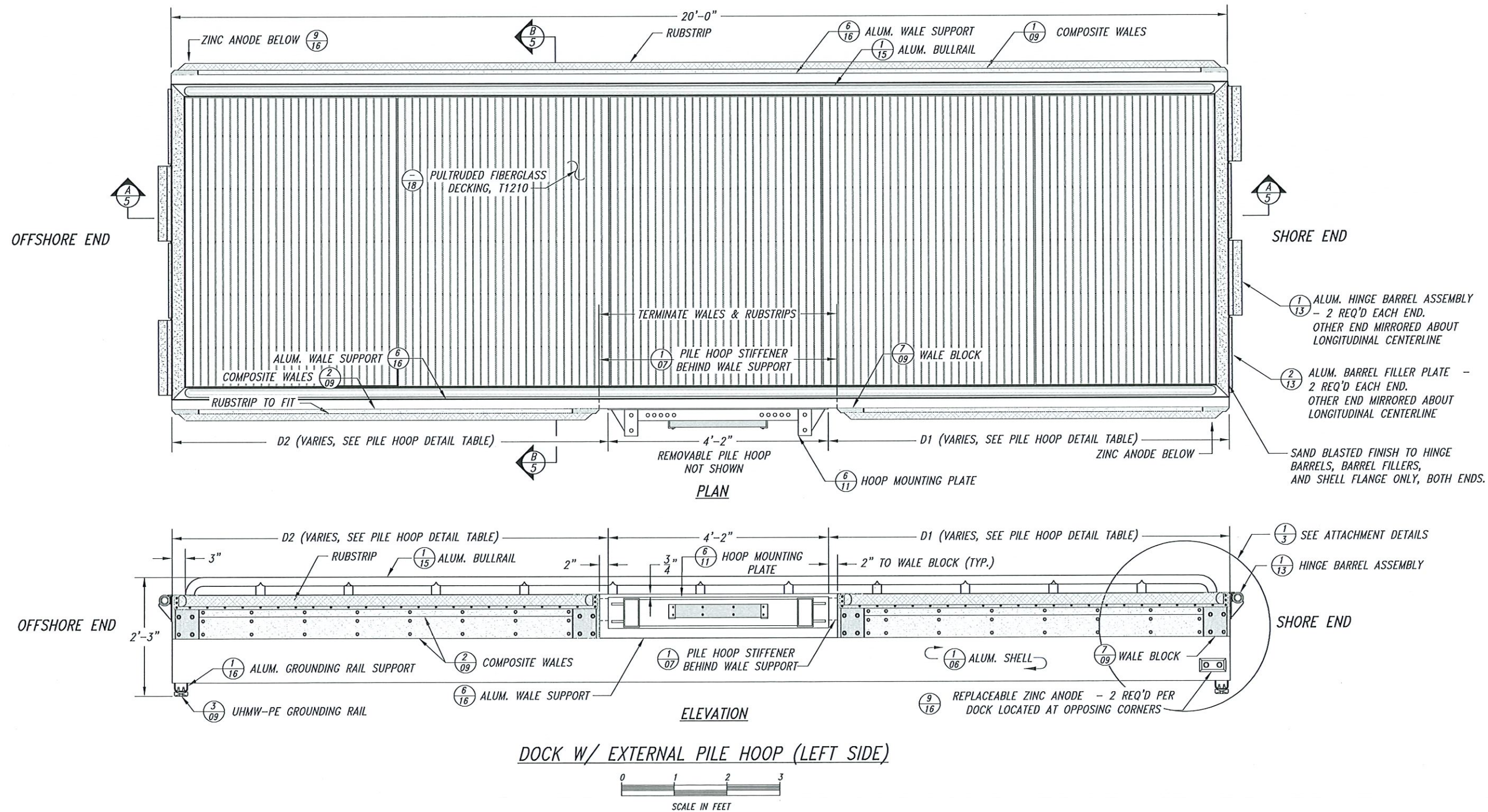

J:\Projects\Cook Park Ramp\1730 - Boarding Dock Replacement\Engineering\Drawings\04.3 - Plan & Profile (Type A - EPH Left).dwg



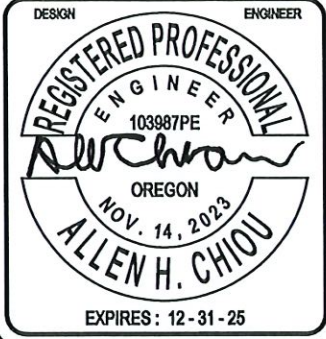

FINAL CHECK SIGNATURE  
*Allen H. Chiu*

DESIGNER: ALLEN C.  
 DRAFTER: ALLEN C.  
 DATE: 8/15/24

SHEET STATUS  
**FINAL**  
 AS ADVERTISED



PROJECT LOCATION, WATERBODY & FACILITY OWNER:  
**COOK PARK RAMP, TUALATIN RIVER - MILE 9.8**  
 CITY OF TIGARD

SHEET DESCRIPTION:  
**ALUMINUM BOARDING DOCK SECTIONS**

SHEET NUMBER  
**05**

SHEET 05 OF 20  
 DRAWING NO.  
 3403 - 1730 - 05

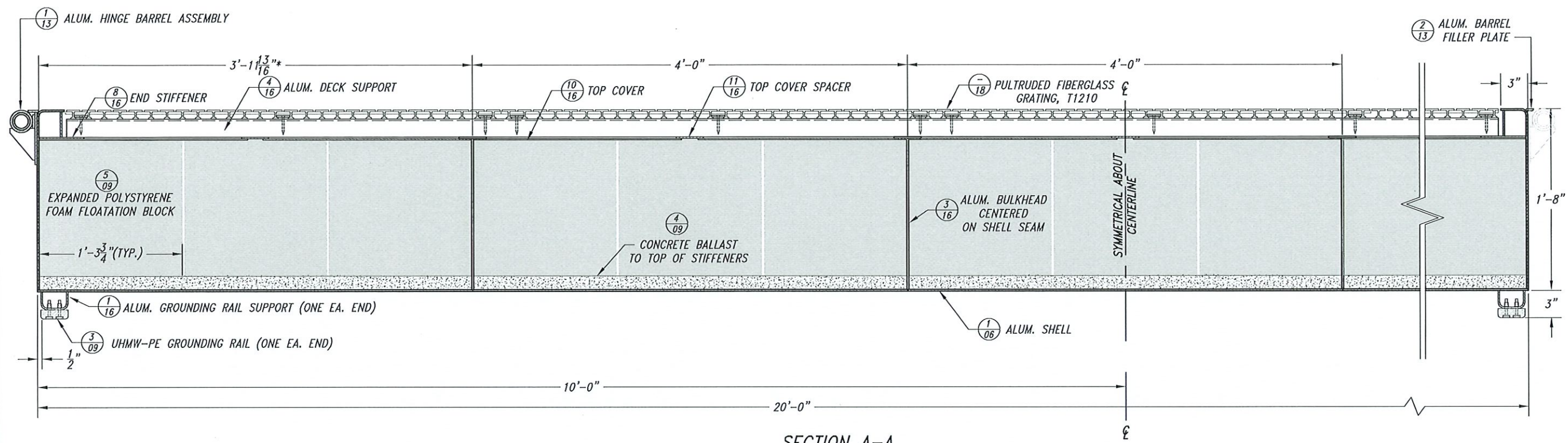

**SECTION A-A**  
 SCALE IN INCHES  
 0 6 12 18

\* MEASURED FROM INSIDE OF SHELL

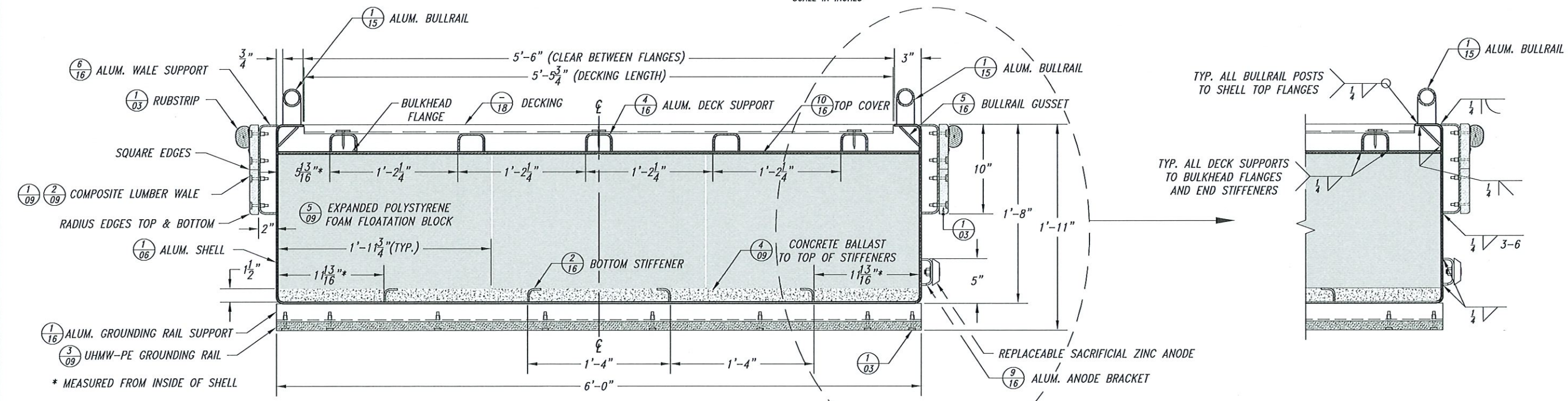

**SECTION B-B**  
 SCALE IN INCHES  
 0 6 12 18

**MISC. WELDING DETAILS**

**NOTES:**  
 1. ALL PLATE, FLAT BAR, AND FORMED SHAPES SHALL BE 5086 ALUMINUM ALLOY PER SPECIFICATIONS.  
 2. ALL ROUND TUBE SHALL BE 6061 ALUMINUM ALLOY PER SPECIFICATIONS.



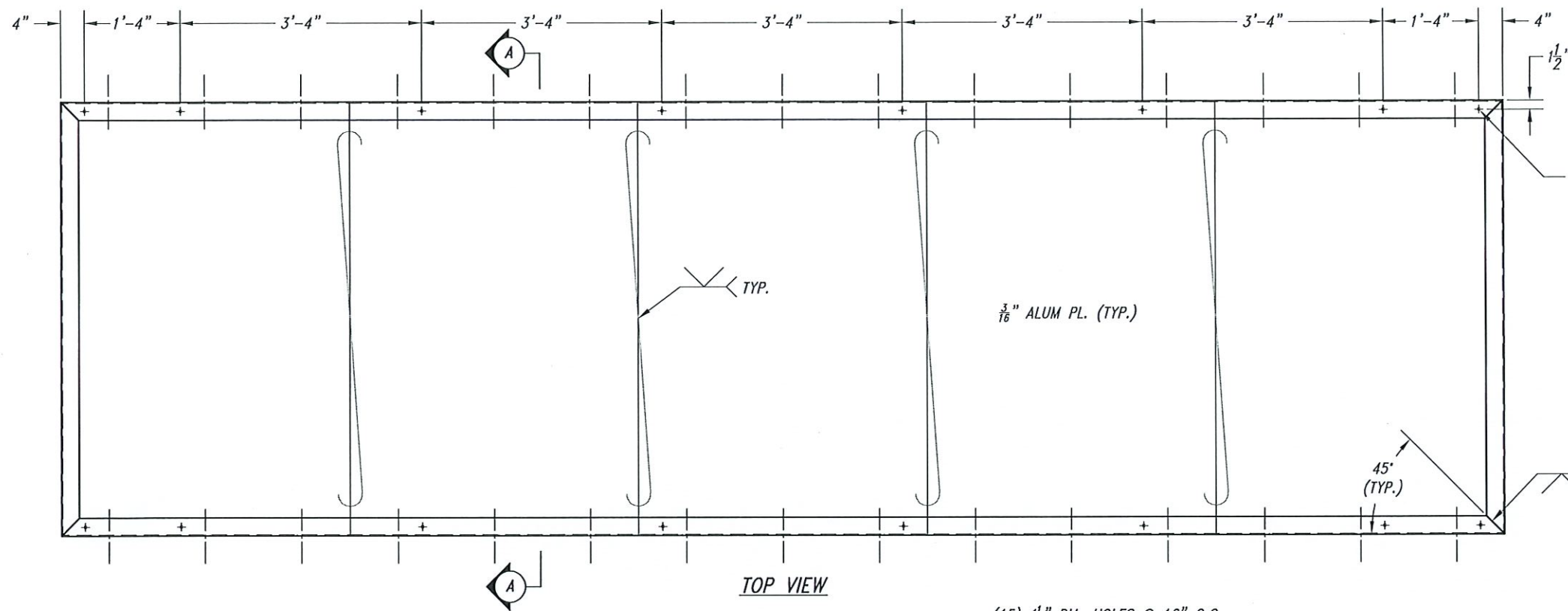

**NOTES:**  
 1. ALL PLATE, FLAT BAR, AND FORMED SHAPES SHALL BE 5086 ALUMINUM ALLOY PER SPECIFICATIONS.  
 2. ALL ROUND TUBE SHALL BE 6061 ALUMINUM ALLOY PER SPECIFICATIONS.

(8) - 1/2" Ø BULLRAIL VENT HOLES, TYP. EACH SIDE

EACH SHELL SECTION (BOTTOM, SIDES AND TOP FLANGES) SHALL BE FORMED BY BENDING 4' x 10' OR 8' x 10' SHEETS OF ALUM. PLATE CUT TO LENGTH TO MEET DIMENSION REQUIREMENTS. ALL BENDS SHALL BE 90° WITH MAX. 1/2" INSIDE RADII. SHELL SECTIONS SHALL NOT BE FABRICATED FROM SEPARATE PIECES WELDED TOGETHER.

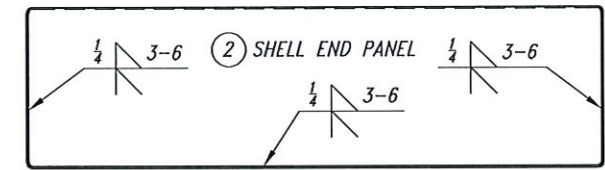
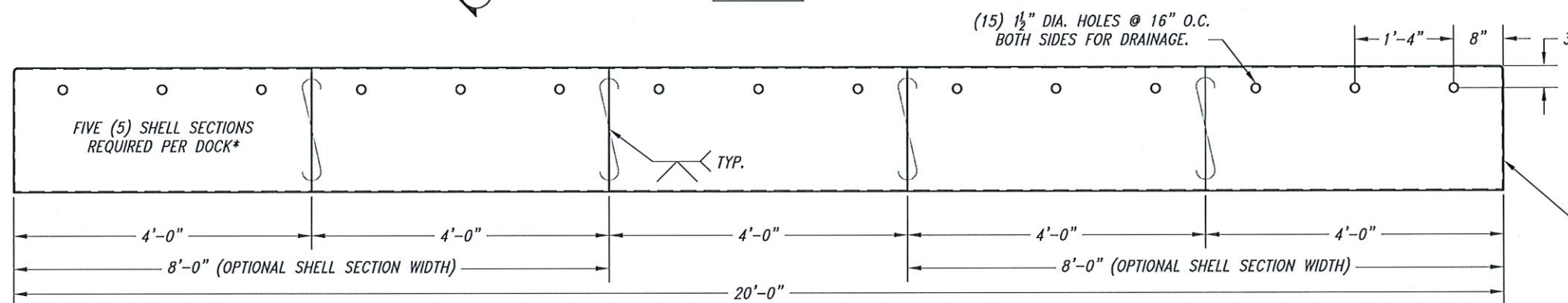

SHELL END PANEL INSET AND FLUSH WITH END OF SHELL

\*THREE (3) SHELL SECTIONS REQUIRED PER DOCK IF USING A COMBINATION OF 8' AND 4' WIDE SECTIONS

① SHELL DETAILS (TYPE "A" DOCK)

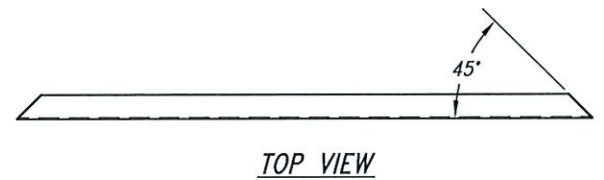
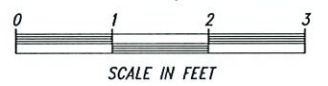

TOP VIEW

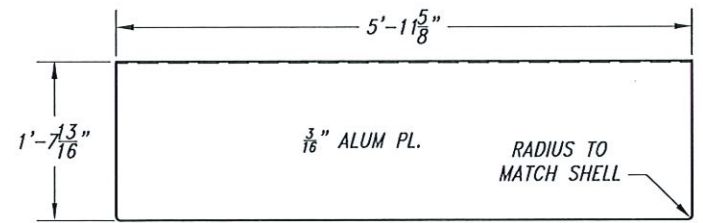

END VIEW

② SHELL END PANEL

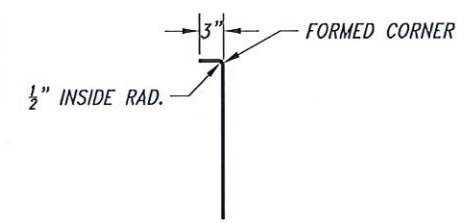

SIDE VIEW

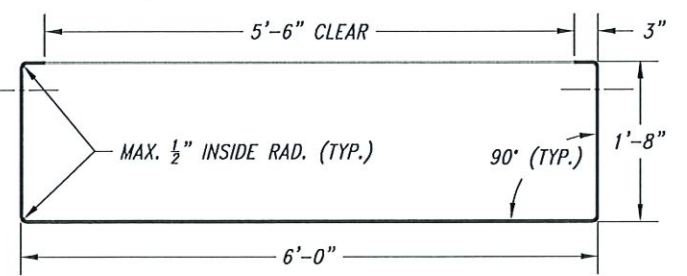

SECTION A-A

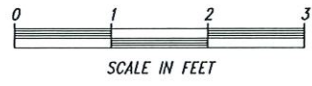

FINAL CHECK SIGNATURE  
 Allen Chiou

DESIGNER: ALLEN C.  
 DRAFTER: ALLEN C.  
 DATE: 8/15/24

SHEET STATUS  
**FINAL**  
 AS ADVERTISED



PROJECT LOCATION, WATERBODY & FACILITY OWNER  
 COOK PARK RAMP, TUALATIN RIVER - MILE 9.8  
 CITY OF TIGARD

SHEET DESCRIPTION:  
 SHELL DETAILS (TYPE "A" DOCK)

SHEET NUMBER  
**06**

SHEET 06 OF 20  
 DRAWING NO.  
 3403-1730-06



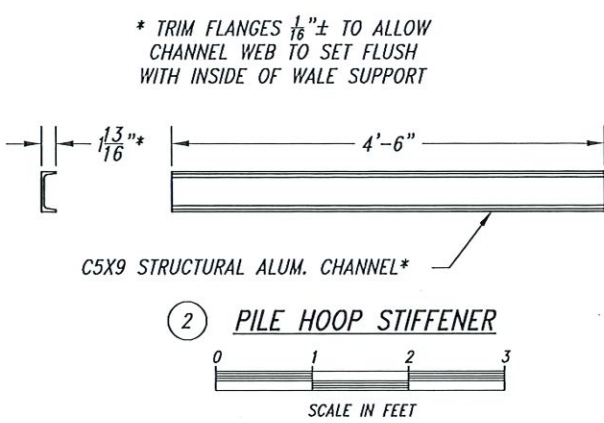
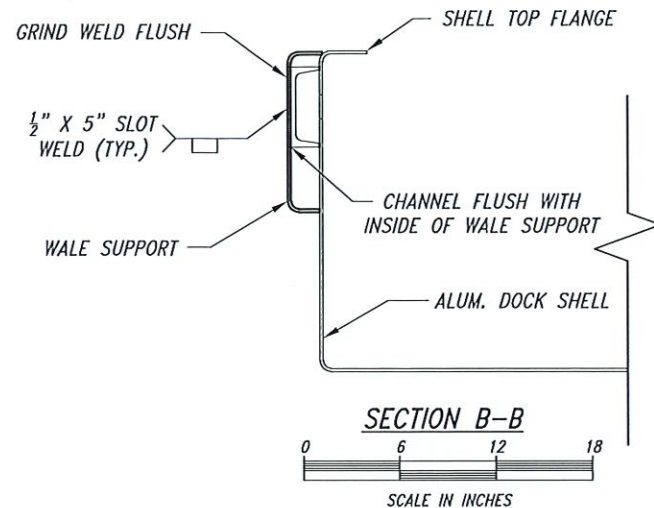
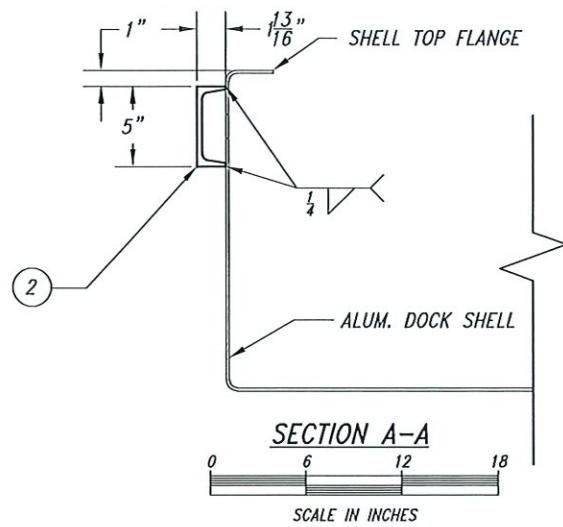

**HOOP STIFFENER TABLE**

DOCK No.	D1	D2
DOCK 1	7'-9"	7'-9"
DOCK 4	6'-3"	9'-3"
DOCK 5	5'-5 7/8"	10'-1/8"

D1 = DISTANCE MEASURED FROM SHORE END OF DOCK  
 D2 = DISTANCE MEASURED FROM OFFSHORE END OF DOCK

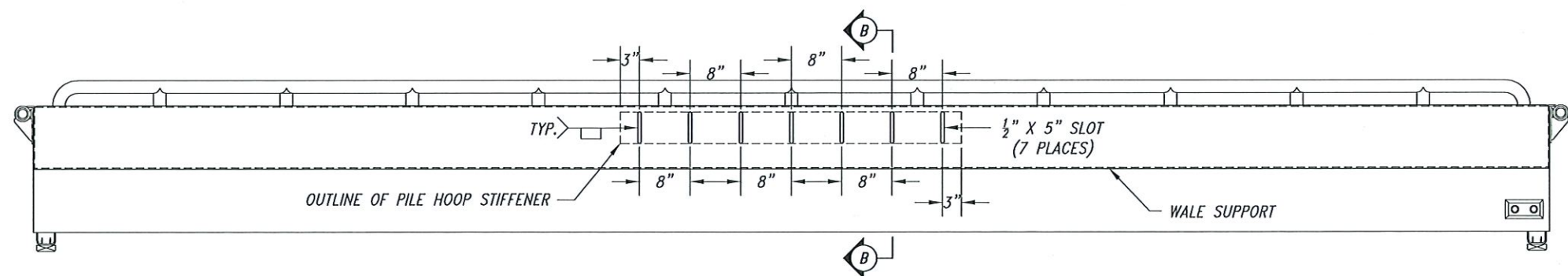
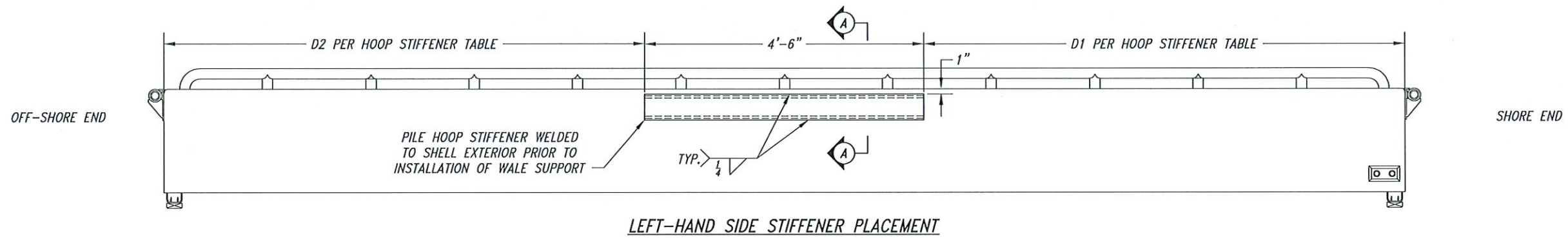

① **PILE HOOP STIFFENER LAYOUT & DETAILS**

DESIGN ENGINEER  
**REGISTERED PROFESSIONAL ENGINEER**  
 103987PE  
*Allen Chou*  
 OREGON  
 NOV. 14, 2023  
**ALLEN H. CHIOU**  
 EXPIRES: 12-31-25

FINAL CHECK SIGNATURE  
*Allen Chou*  
 DESIGNER: ALLEN C.  
 DRAFTER: ALLEN C.  
 DATE: 8/15/24

SHEET STATUS  
**FINAL**  
 AS ADVERTISED

OREGON STATE MARINE BOARD

PROJECT LOCATION, WATERBODY & FACILITY OWNER  
**COOK PARK RAMP, TUALATIN RIVER - MILE 9.8**  
**CITY OF TIGARD**  
 SHEET DESCRIPTION  
**PILE HOOP STIFFENER LAYOUT & DETAILS**

SHEET NUMBER  
**07**  
 SHEET 07 OF 20  
 DRAWING NO.  
**3403 - 1730 - 07**

J:\Projects\Cook Park Ramp\1730 - Boarding Dock Replacement\Engineering\Drawings\07.3 - Pile Hoop Stiffener (Type A - EPH only).dwg





FINAL CHECK SIGNATURE  
*Allen Chio*  
 DESIGNER: ALLEN C.  
 DRAFTER: ALLEN C.  
 DATE: 8/15/24

SHEET STATUS  
**FINAL**  
 AS ADVERTISED



PROJECT LOCATION: WATERBODY & FACILITY OWNER:  
**COOK PARK RAMP, TUALATIN RIVER - MILE 9.8**  
**CITY OF TIGARD**  
 SHEET DESCRIPTION:  
**STRUCTURAL LAYOUT**

SHEET NUMBER  
**08**  
 SHEET 08 OF 20  
 DRAWING NO.  
 3403 - 1730 - 08

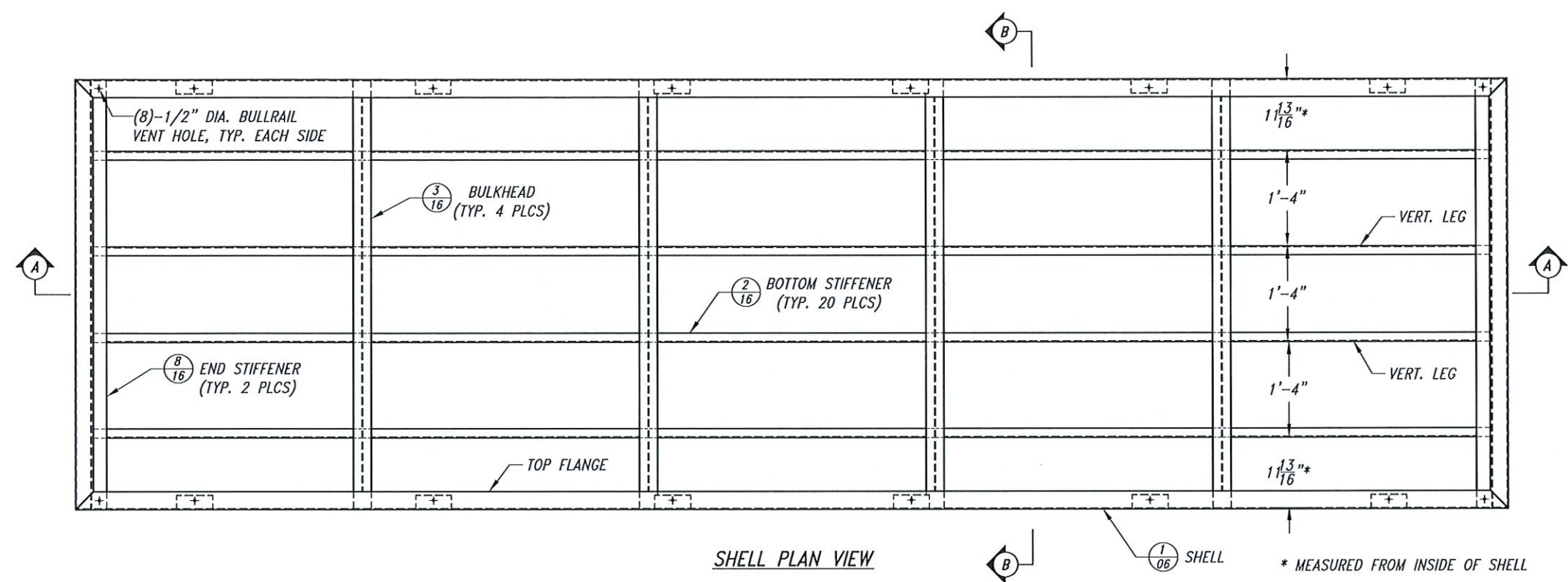

SHELL PLAN VIEW

\* MEASURED FROM INSIDE OF SHELL

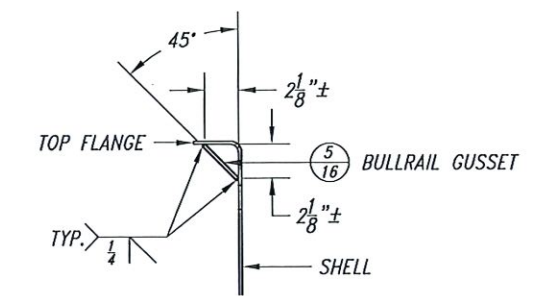

2 BULLRAIL GUSSET WELDMENT

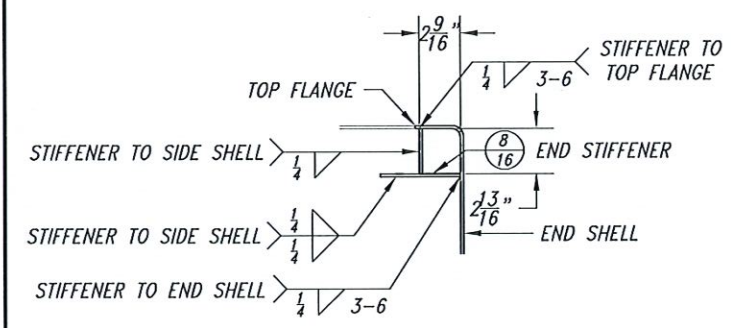
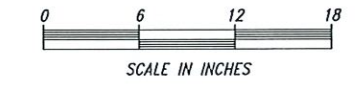

1 END STIFFENER WELDMENT

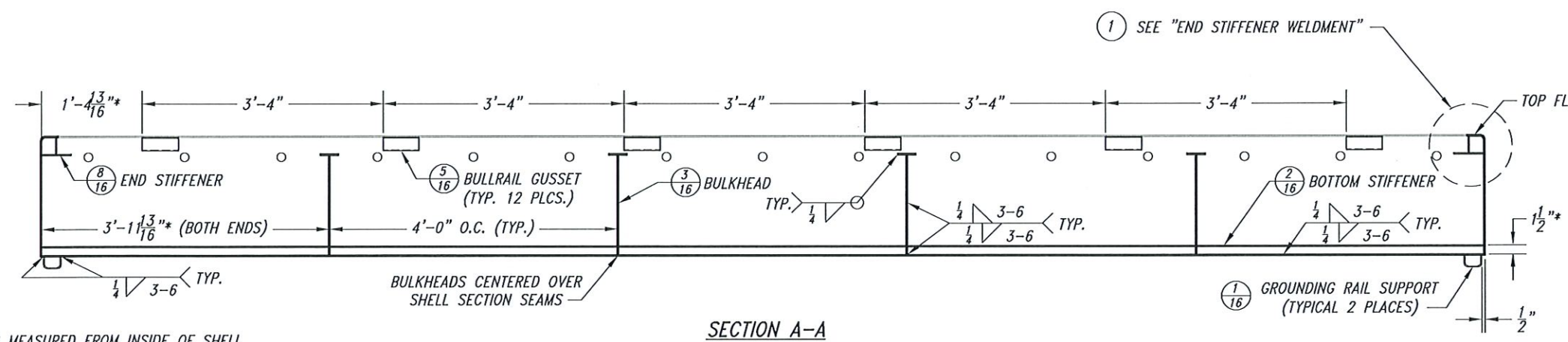
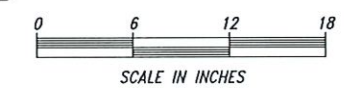

SECTION A-A

\* MEASURED FROM INSIDE OF SHELL

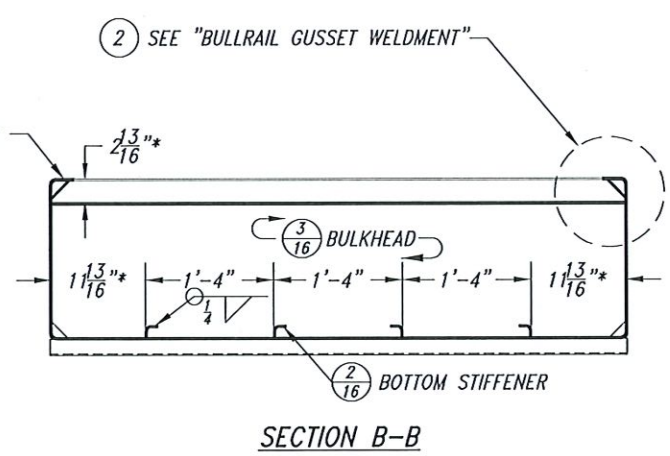

SECTION B-B

\* MEASURED FROM INSIDE OF SHELL

STRUCTURAL LAYOUT



NOTES:  
 1. ALL PLATE, FLAT BAR, AND FORMED SHAPES SHALL BE 5086 ALUMINUM ALLOY PER SPECIFICATIONS.  
 2. ALL ROUND TUBE SHALL BE 6061 ALUMINUM ALLOY PER SPECIFICATIONS.



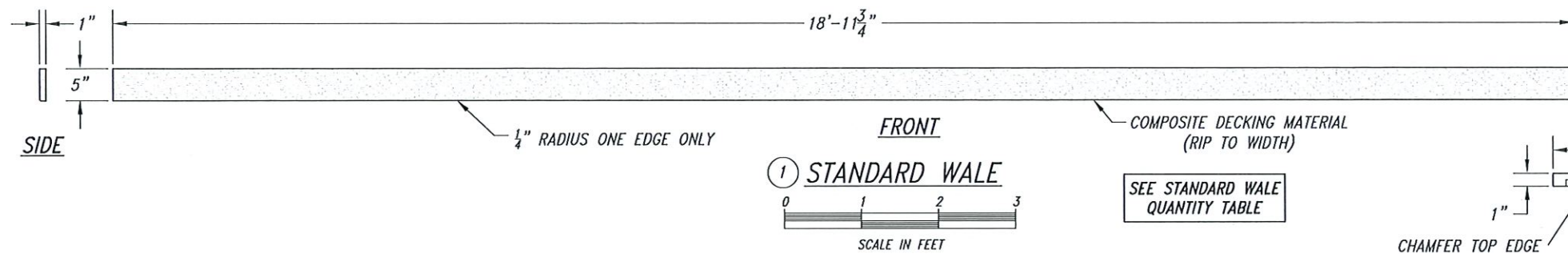

1 STANDARD WALE

SEE STANDARD WALE QUANTITY TABLE

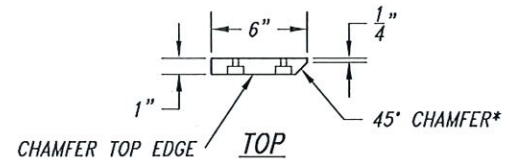

7 WALE BLOCK

4 PER DOCK W/O PILE HOOP  
6 PER DOCK W/ PILE HOOP

STANDARD WALE QUANTITY TABLE

DOCK No.	QTY
DOCK 1	2
DOCK 2	4
DOCK 3	4
DOCK 4	2
DOCK 5	2

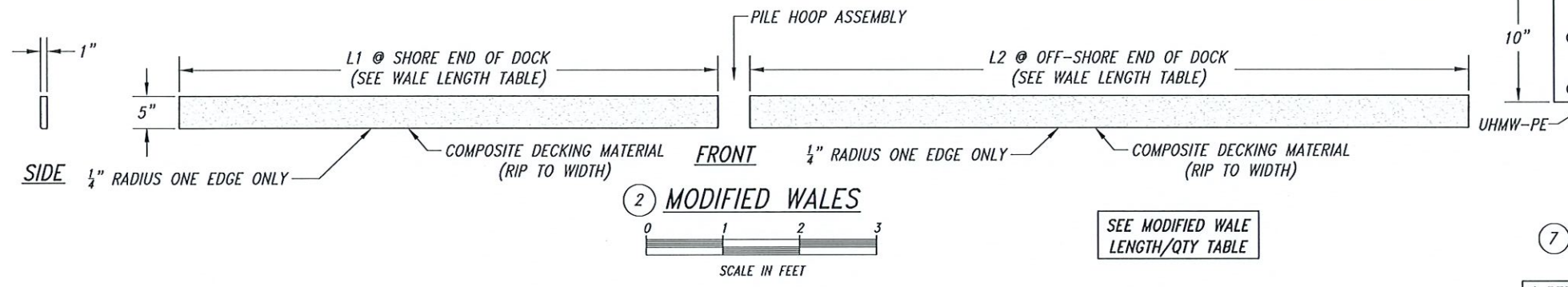

2 MODIFIED WALES

SEE MODIFIED WALE LENGTH/QTY TABLE

MODIFIED WALE LENGTH/QTY TABLE

DOCK No.	L1	QTY	L2	QTY
DOCK 4	0'-0"	0	8'-2 3/4"	2
DOCK 5	4'-5 5/8"	2	8'-11 7/8"	2

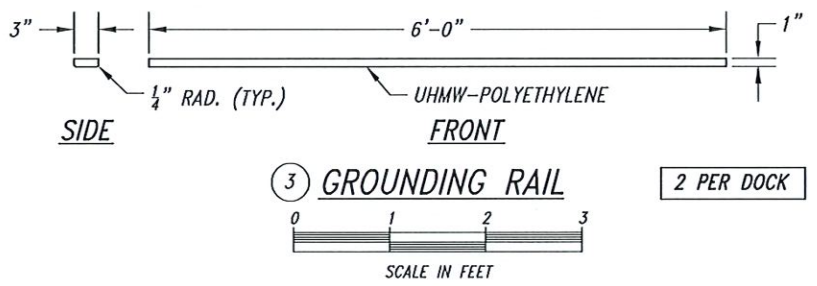

3 GROUNDING RAIL

2 PER DOCK

9 BLOCKS PER BAY BETWEEN BULKHEADS. PLACE PER SEQUENCE SHOWN (6 BLOCKS AGAINST BULKHEADS FIRST, THEN 2 BLOCKS AGAINST SHELL SIDES, THEN CENTER BLOCK LAST).

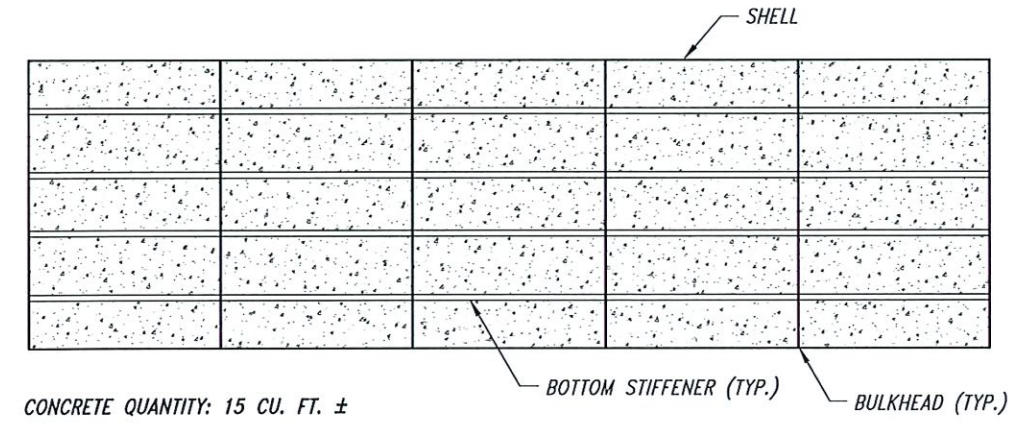

PLAN VIEW

4 CONCRETE BALLAST PLACEMENT STANDARD DOCK

NTS

PLACE CONCRETE BALLAST FLUSH WITH TOP OF BOTTOM STIFFENERS (1 1/2" DEPTH) IN ALL BAYS. APPLY BARRIER COATING TO ALL INTERIOR SURFACES IN CONTACT WITH CONCRETE PRIOR TO PLACING CONCRETE.

CONCRETE QUANTITY: 15 CU. FT. ±

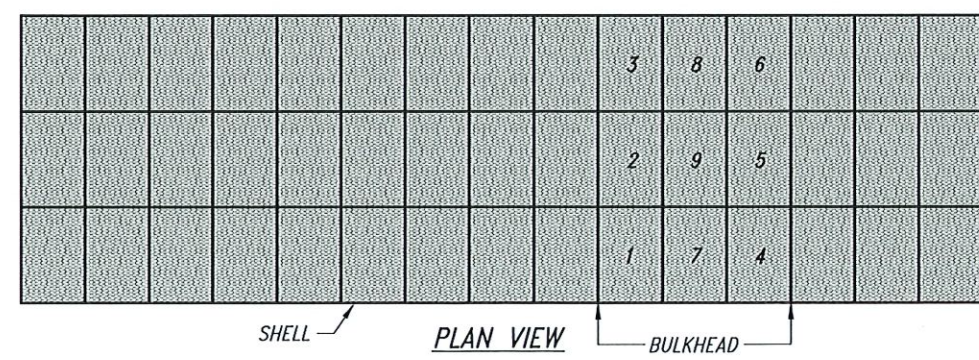

PLAN VIEW

FOAM PLACEMENT SEQUENCE

NTS

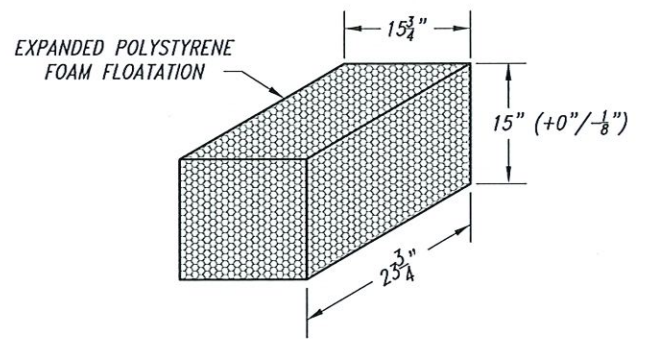

5 FOAM BLOCK DETAILS

SCALE IN FEET

45 PER DOCK



FINAL CHECK SIGNATURE  
Allen H. Chiou

DESIGNER: ALLEN C.  
DRAFTER: ALLEN C.  
DATE: 8/15/24

SHEET STATUS  
**FINAL**  
AS ADVERTISED



PROJECT LOCATION, WATERBODY & FACILITY OWNER:  
COOK PARK RAMP, TUALATIN RIVER - MILE 9.8  
CITY OF TIGARD

SHEET DESCRIPTION:  
FOAM, CONCRETE, WALE DETAILS

SHEET NUMBER  
**09**

SHEET 09 OF 20  
DRAWING NO. 3403-1730-09

J:\Projects\Cook Park Ramp\1730 - Boarding Dock Replacement\Engineering\Drawings\09.a - Concrete, Foam, Wale Details (Type A for EPH only).dwg





FINAL CHECK SIGNATURE  
*Allen Chio*  
 DESIGNER: ALLEN C.  
 DRAFTER: ALLEN C.  
 DATE: 8/15/24

SHEET STATUS  
**FINAL**  
 AS ADVERTISED



PROJECT LOCATION, WATERBODY & FACILITY OWNER:  
**COOK PARK RAMP, TUALATIN RIVER - MILE 9.8**  
 CITY OF TIGARD  
 SHEET DESCRIPTION:  
**TOPSIDE LAYOUT (TYPE "A" DOCK)**

SHEET NUMBER  
**10**  
 SHEET 10 OF 20  
 DRAWING NO.  
 3403 - 1730 - 10

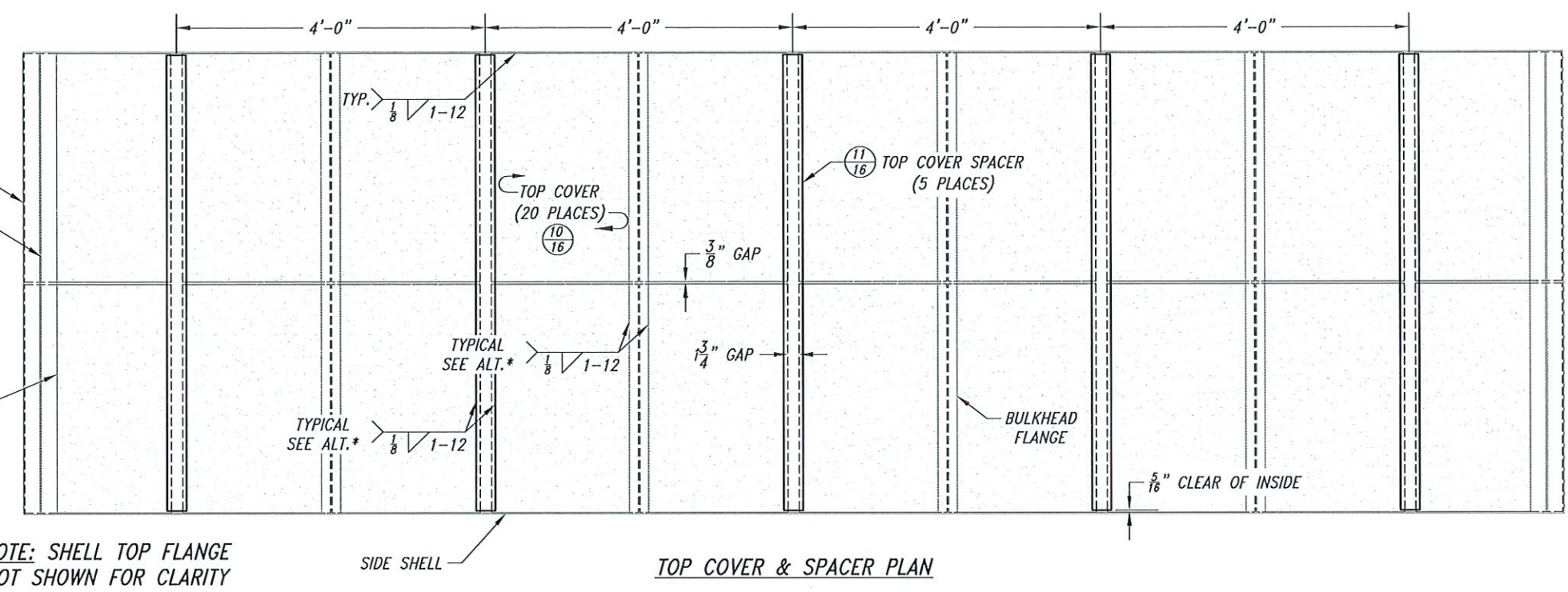

PLACE TOP COVERS ON FOAM WITH ONE EDGE UNDER BULKHEAD FLANGE AND AGAINST BULKHEAD. SLIDE ADJACENT EDGE AGAINST SIDE SHELL. TACK WELD AS SHOWN TAKING CARE TO AVOID/MINIMIZE MELTING OF FOAM. SIDE GAP BETWEEN COVERS WILL BE 1/4" AND END GAP WILL BE 3/8".

CENTER TOP COVER SPACERS OVER SIDE GAP BETWEEN TOP COVERS WITH 5/16" CLEAR FROM SIDE SHELL. TACK WELD AS SHOWN TAKING CARE TO AVOID/MINIMIZE MELTING OF FOAM.

\* AS AN ALTERNATIVE TO TACK WELDING, TOP COVERS MAY BE SCREWED OR RIVETED TO BULKHEAD FLANGES AND SPACERS USING S.S. FASTENERS SPACED 12" O.C.

NOTE: SHELL TOP FLANGE NOT SHOWN FOR CLARITY

TOP COVER & SPACER PLAN

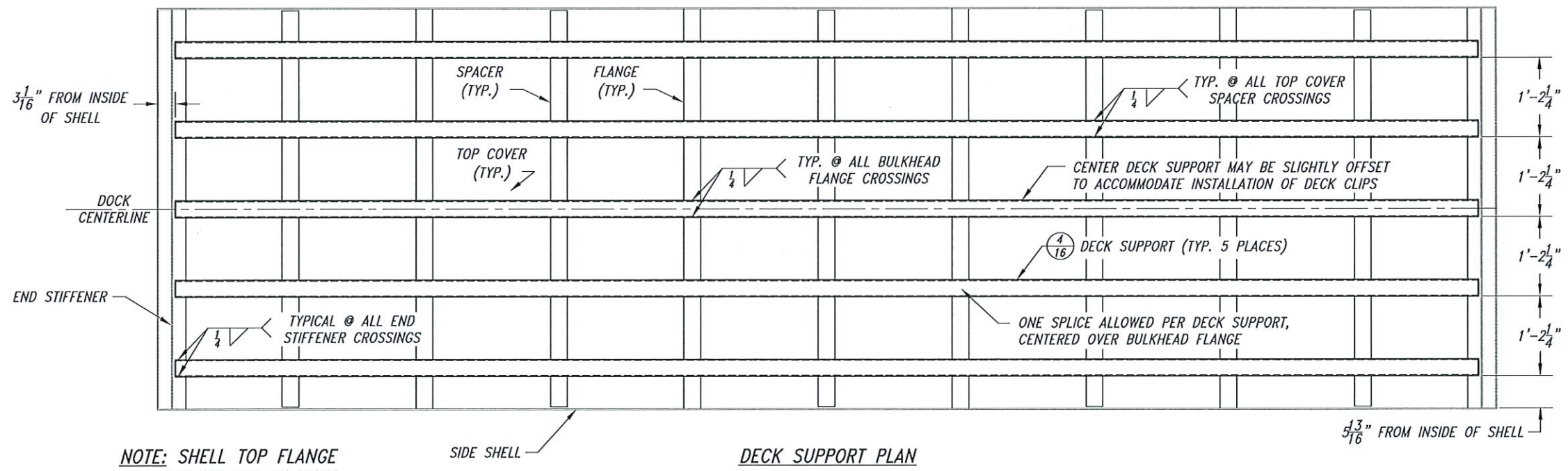

NOTE: SHELL TOP FLANGE NOT SHOWN FOR CLARITY

DECK SUPPORT PLAN

TOPSIDE LAYOUT (TYPE "A" DOCK)



NOTES:  
 1. ALL PLATE, FLAT BAR, AND FORMED SHAPES SHALL BE 5086 ALUMINUM ALLOY PER SPECIFICATIONS.  
 2. ALL ROUND TUBE SHALL BE 6061 ALUMINUM ALLOY PER SPECIFICATIONS.



J:\Projects\Cook Park Ramp\Boarding Dock Replacement\Engineering\Drawings\11.4 - Pile Hoop Mounting Plate & details (Gated ERF).dwg

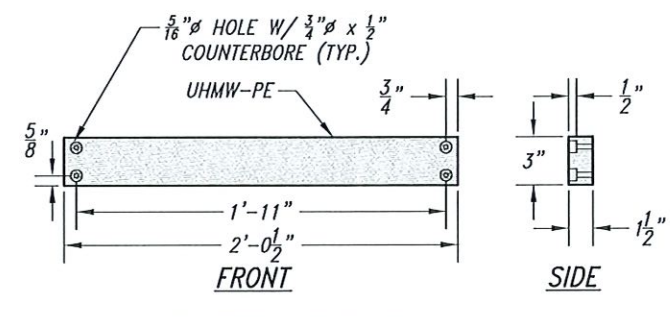
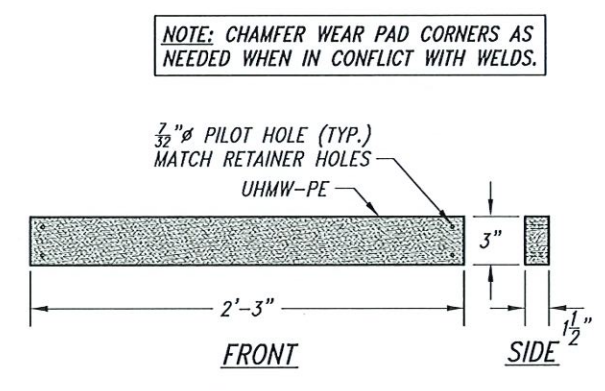
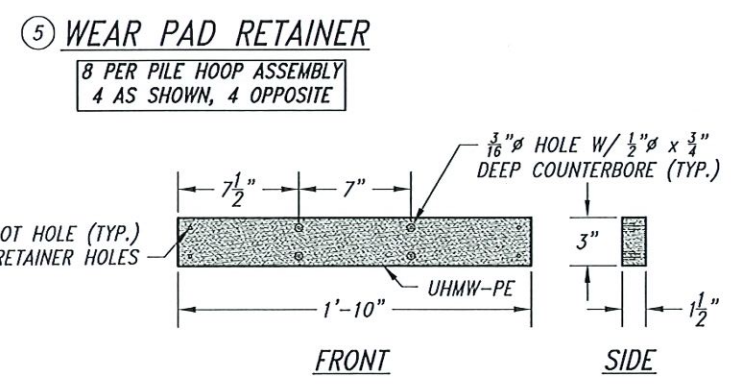
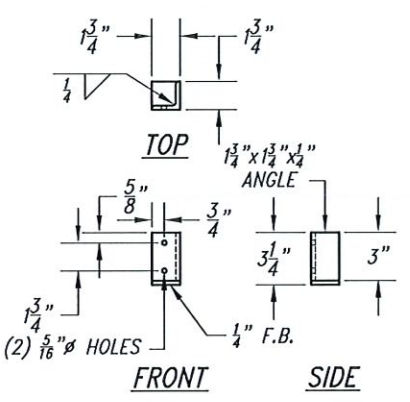
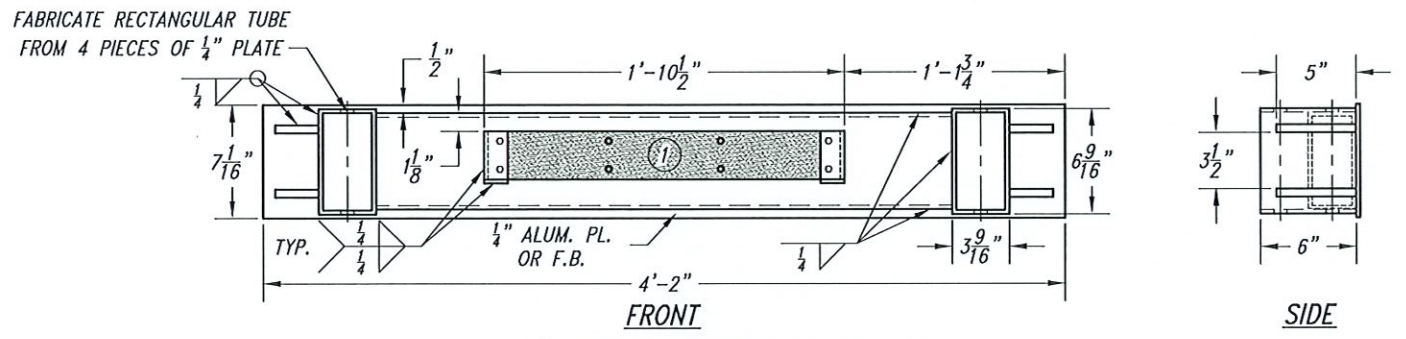
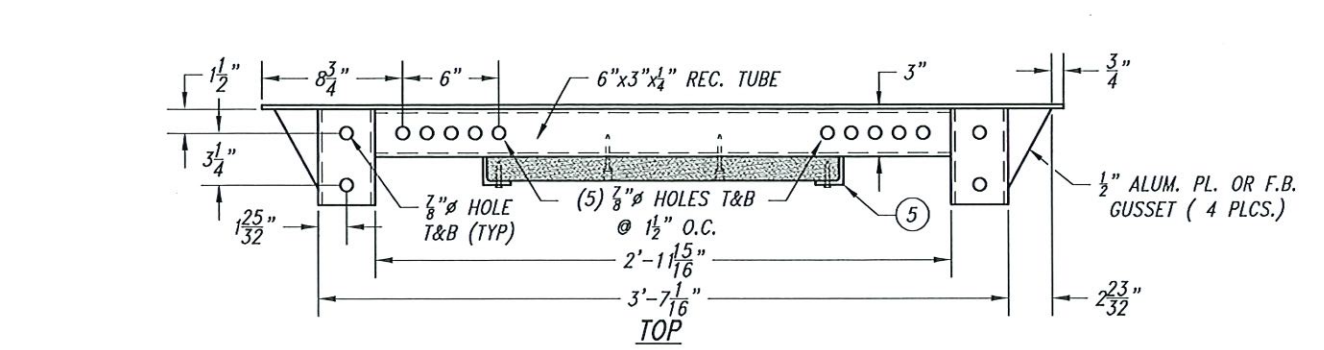

① WEAR PAD 1  
 2 PER PILE HOOP ASSEMBLY

② WEAR PAD 2  
 2 PER PILE HOOP ASSEMBLY

③ WEAR PAD 3  
 2 PER PILE HOOP ASSEMBLY

NOTE: ALL PLATE, FLAT BAR, AND SHAPES SHALL BE 6061 ALUMINUM ALLOY PER SPECIFICATIONS FOR ALL COMPONENTS THIS SHEET ONLY.

PILE HOOP MOUNTING PLATE & DETAILS

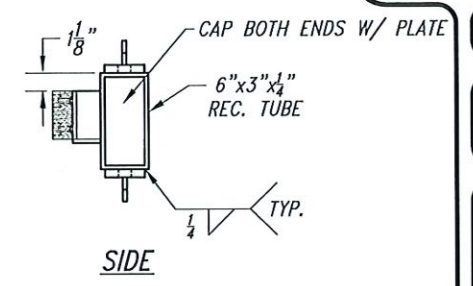
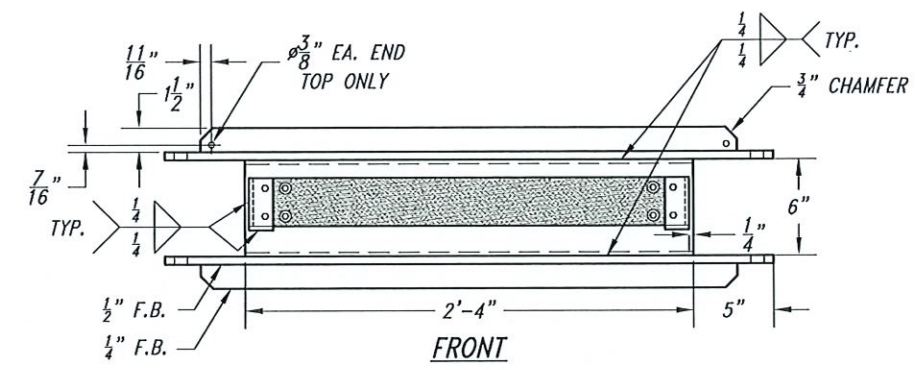
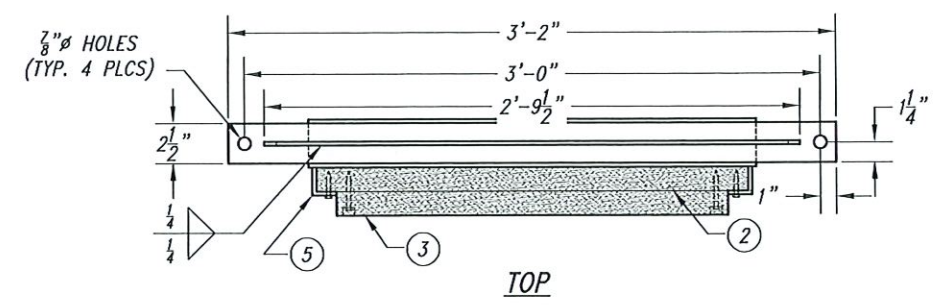
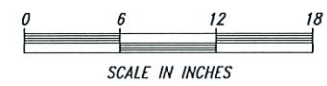

④ ADJUSTABLE WEAR PAD ASSEMBLY  
 2 PER PILE HOOP ASSEMBLY

FOR USE WITH GATED EXTERNAL PILE HOOP

NOTE: CHAMFER WEAR PAD CORNERS AS NEEDED WHEN IN CONFLICT WITH WELDS.

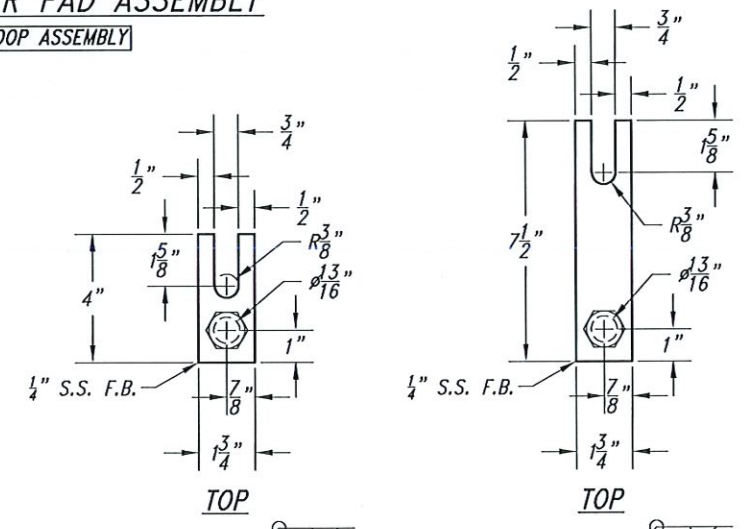

⑦ SHORT BOLT TAB  
 4 PER PILE HOOP ASSEMBLY

⑧ LONG BOLT TAB  
 2 PER PILE HOOP ASSEMBLY

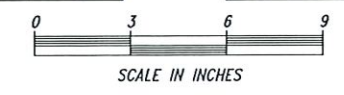

PROVIDE L.W. & NUT FOR OPTIONAL BOLTED CONNECTION





FINAL CHECK SIGNATURE  
*Allen Chiu*

DESIGNER: ALLEN C.  
 DRAFTER: ALLEN C.  
 DATE: 8/15/24

SHEET STATUS  
**FINAL**  
 AS ADVERTISED



PROJECT LOCATION, WATERBODY & FACILITY OWNER  
**COOK PARK RAMP, TUALATIN RIVER - MILE 9.8**  
 CITY OF TIGARD

SHEET DESCRIPTION  
**EXTERNAL PILE HOOP DETAILS**

SHEET NUMBER  
**12**

SHEET 12 OF 20  
 DRAWING NO.  
 3403 - 1730 - 12

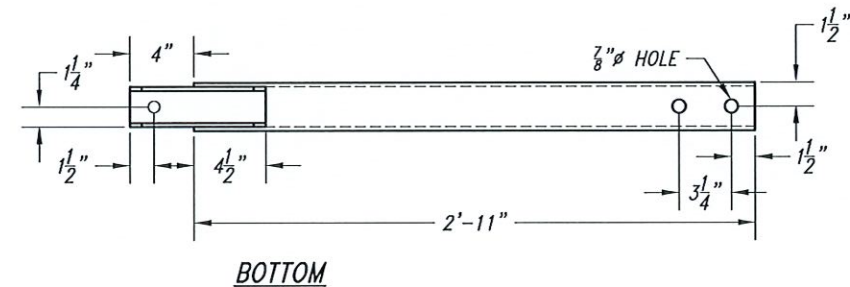
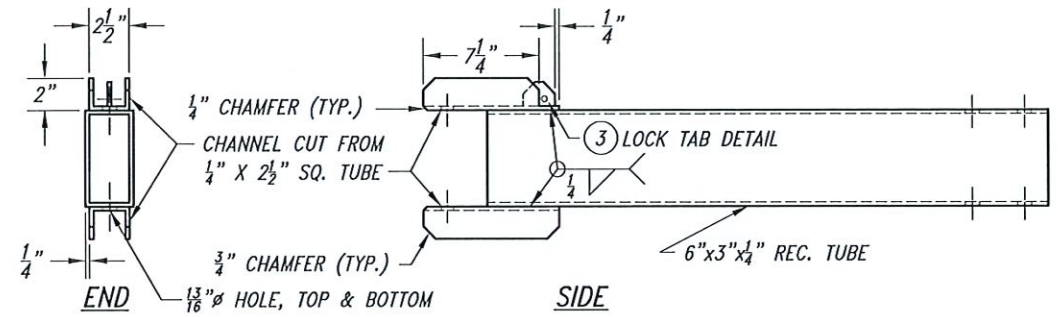
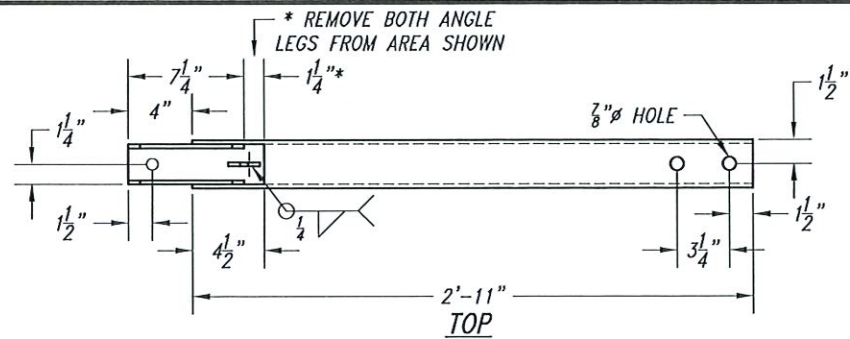

② REMOVABLE HOOP ARM  
 2 PER PILE HOOP ASSEMBLY

0 6 12 18  
 SCALE IN INCHES

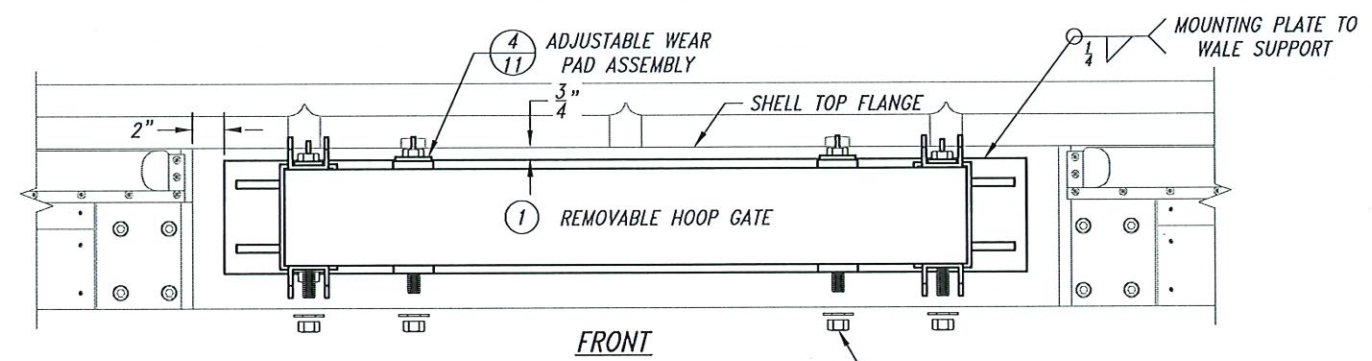
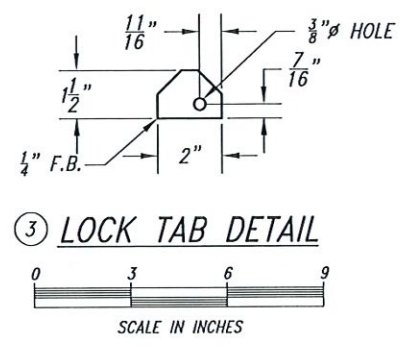
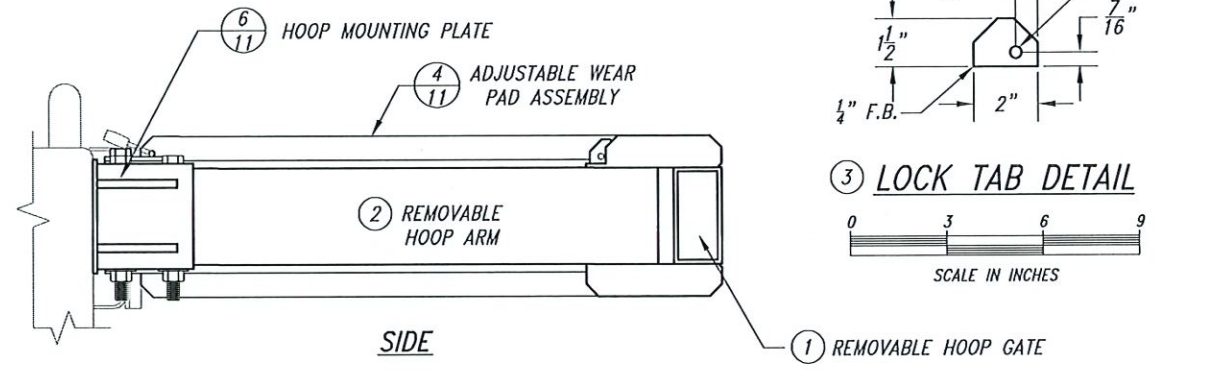

EXTERNAL GATED PILE HOOP ASSEMBLY

PROVIDE L.W. & NUT FOR OPTIONAL BOLTED CONNECTION (6 PLACES)

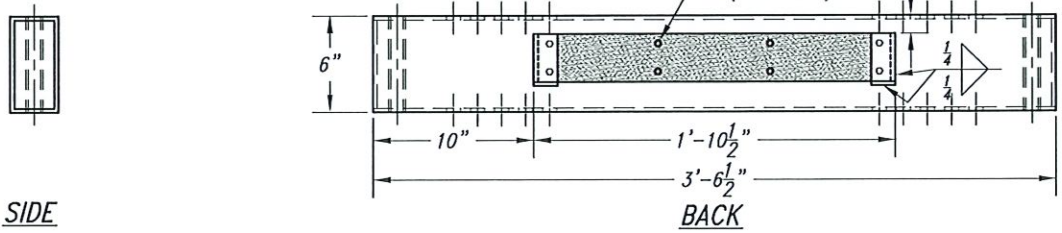
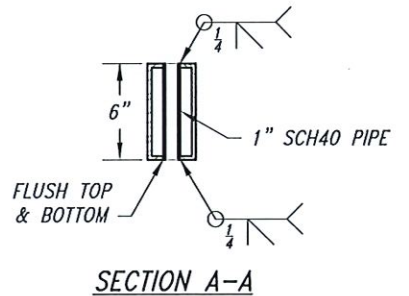
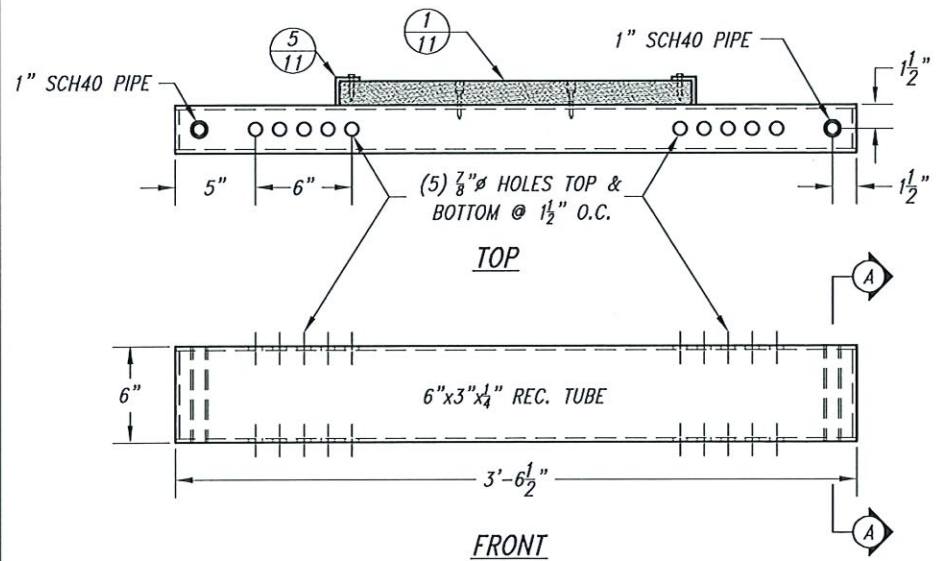

① REMOVABLE HOOP GATE  
 1 PER PILE HOOP ASSEMBLY

0 6 12 18  
 SCALE IN INCHES

NOTE: ALL PLATE, FLAT BAR, AND SHAPES SHALL BE 6061 ALUMINUM ALLOY PER SPECIFICATIONS FOR ALL COMPONENTS THIS SHEET ONLY.

J:\Projects\Cook Park Ramp\1730 - Boarding Dock Replacement\Engineering\Drawings\12.4 - External Pile Hoop Details (Gated).dwg



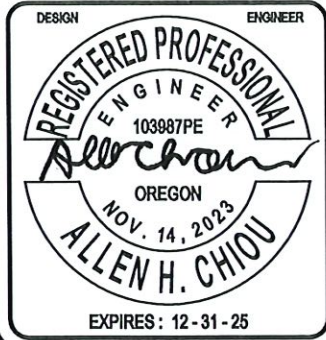

FINAL CHECK SIGNATURE  
*Allen Chiou*  
 DESIGNER: ALLEN C.  
 DRAFTER: ALLEN C.  
 DATE: 8/15/24

SHEET STATUS  
**FINAL**  
 AS ADVERTISED

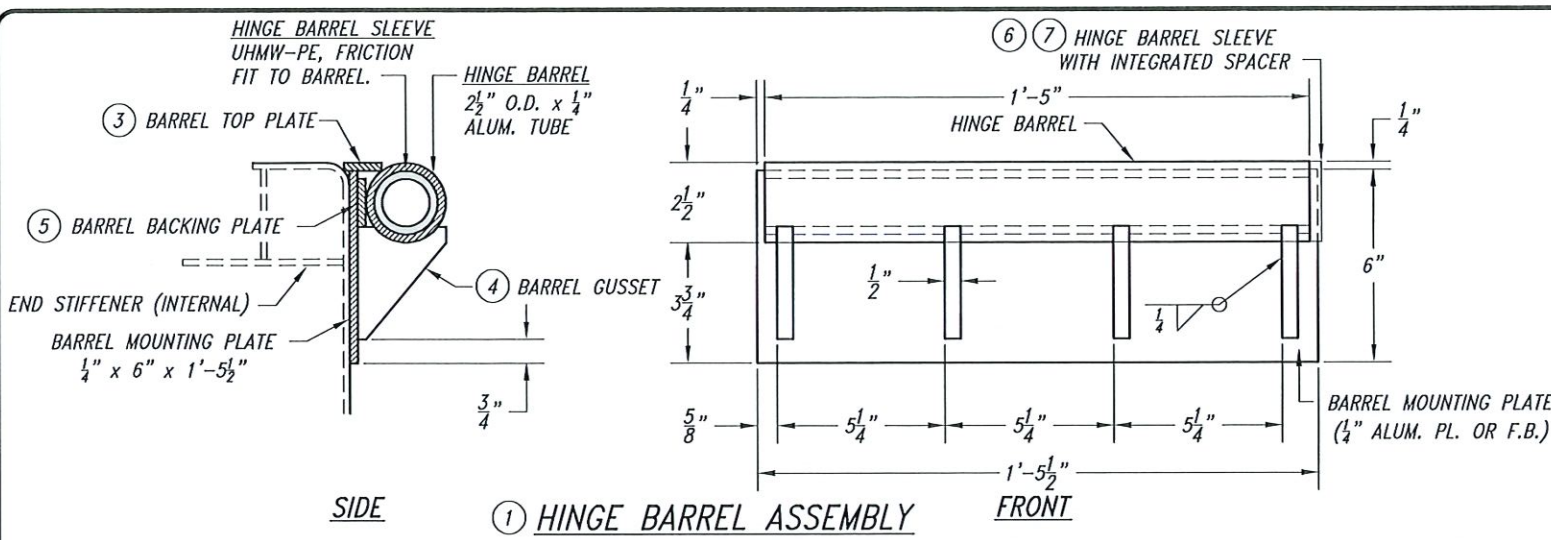

① HINGE BARREL ASSEMBLY

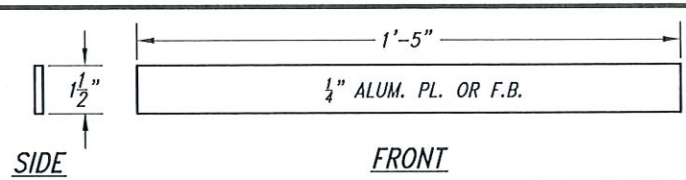

⑤ BARREL BACKING PLATE

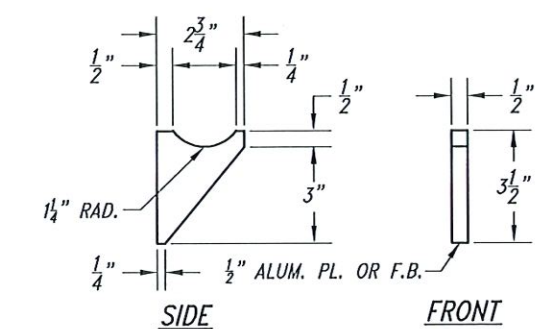

④ BARREL GUSSET

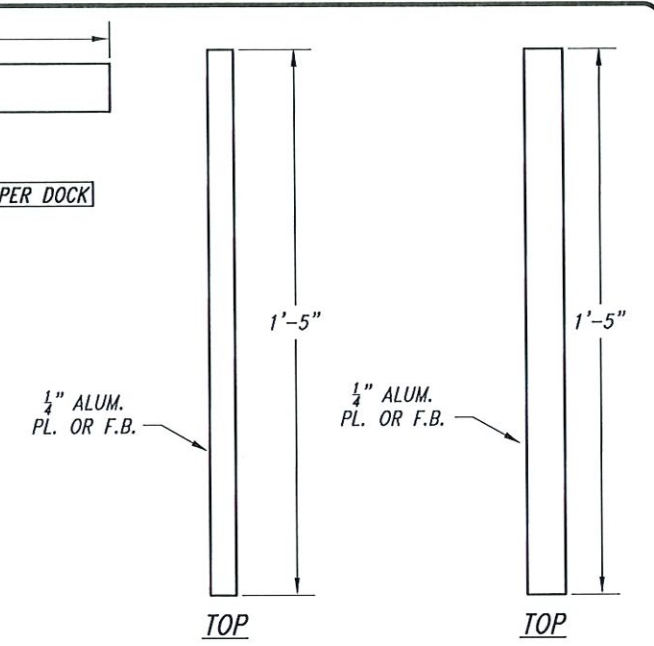

② BARREL FILLER PLATE

③ BARREL TOP PLATE

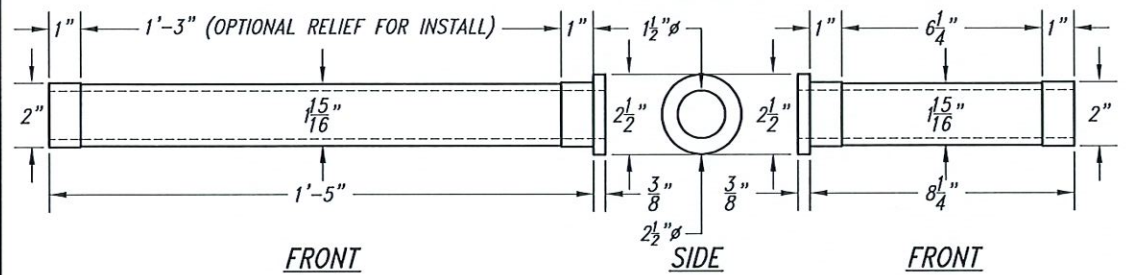

⑥ BARREL SLEEVE

MILL FROM 2 1/2" O.D. X 1 1/2" I.D. UHMW-PE TUBE BLANK. FRICTION FIT TO BARRELS

⑦ SPLIT BARREL SLEEVE

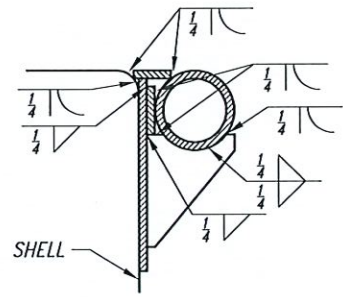

BARREL WELDMENT

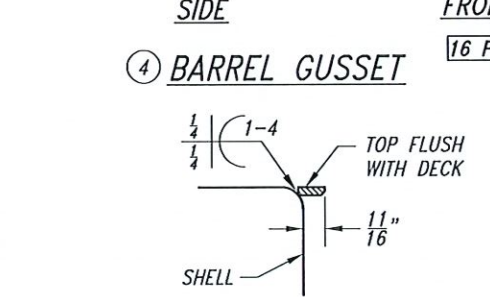

BARREL FILLER PLATE WELDMENT

\* SEE BARREL FILLER PLATE WELDMENT FOR OVERHANG DISTANCE. ADJUST AS NEEDED.

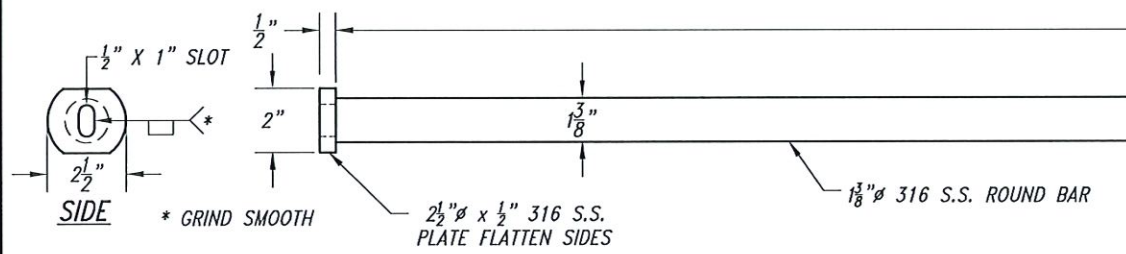

TOP HINGE PIN

HINGE PIN ASSEMBLY INCLUDES:  
 (1) HINGE PIN  
 (1) 316 S.S. F.W.,  
 (1) 1/2" 316 S.S. BOLT, L.W., & NUT  
 (1) PADLOCK PER SPEC.

WASHER REQUIREMENTS:

- MATERIAL - 316 S.S. FLAT WASHER
- 0.13 TO 0.19 THICKNESS
- 2 1/2" OUTSIDE DIAMETER
- 1 3/8" TO 1 1/2" INSIDE DIAMETER
- CUSTOM MILL OR USE 1 1/4" SAE WASHER (NOTE: 1 1/4" SAE HAS A 1.375" I.D. {+0.030 TO -0.007} WHICH MAY REQUIRE REAMING TO FIT.

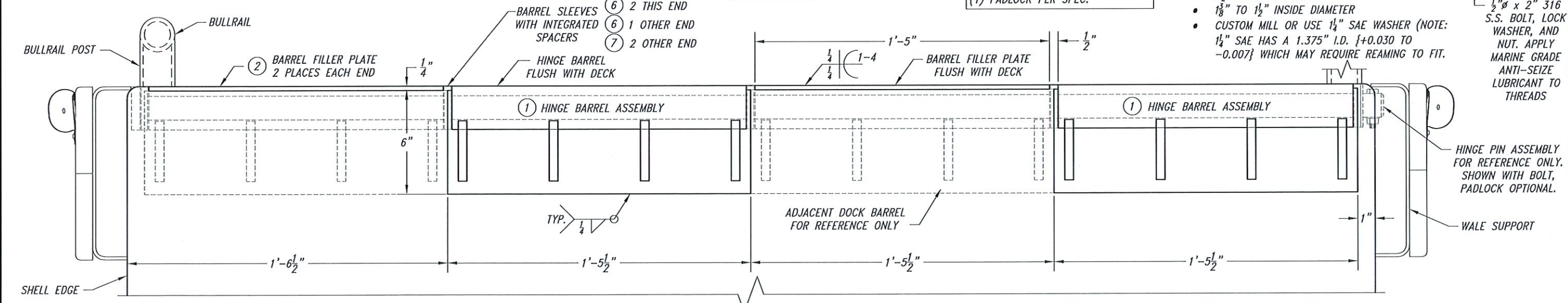

HINGE BARREL ASSEMBLY DETAILS

NOTE: ALL PLATE, FLAT BAR, AND ROUND TUBE SHALL BE 6061 ALUMINUM ALLOY PER SPECIFICATIONS FOR ALL COMPONENTS (EXCEPT HINGE PIN) THIS SHEET ONLY.

NOTE: HINGE BARREL ASSEMBLIES ON OTHER END OF DOCK ARE OPPOSITE FROM SHOWN.

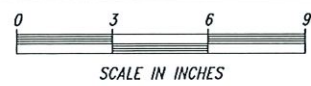

PROJECT LOCATION: WATERBODY & FACILITY OWNER:  
 COOK PARK RAMP, TUALATIN RIVER - MILE 9.8  
 CITY OF TIGARD

SHEET DESCRIPTION:  
 HINGE BARREL ASSEMBLY DETAILS

SHEET NUMBER  
**13**  
 SHEET 13 OF 20  
 DRAWING NO.  
 3403 - 1730 - 13

J:\Projects\Cook Park Ramp\1730 - Boarding Dock Replacement\Engineering\Drawings\13.0 - Hinge Barrel Assembly Details.dwg



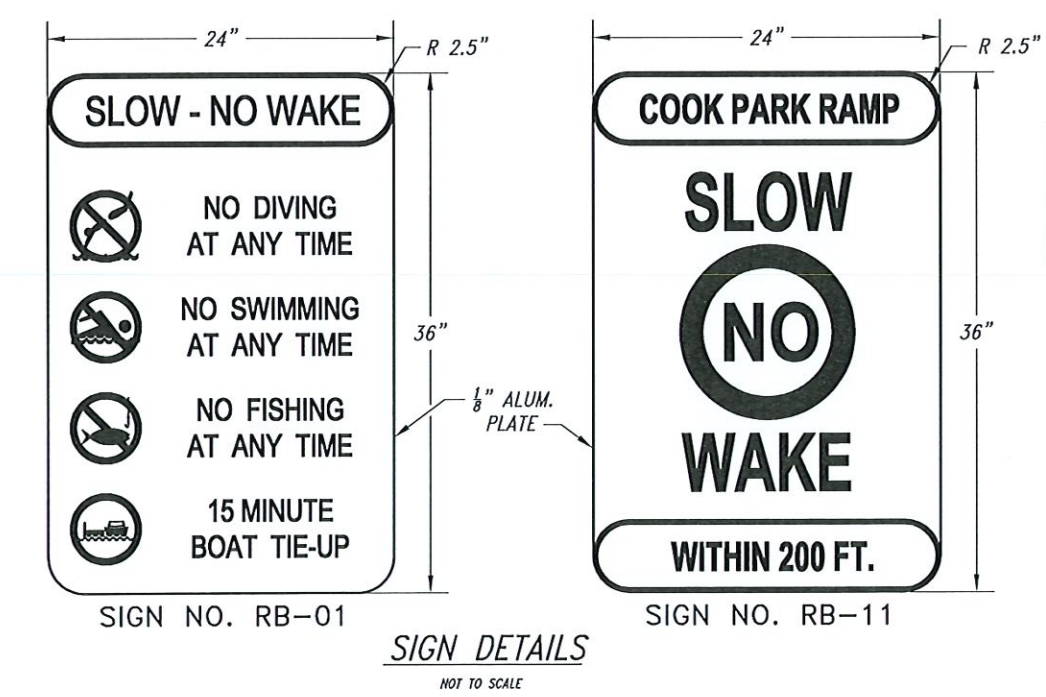
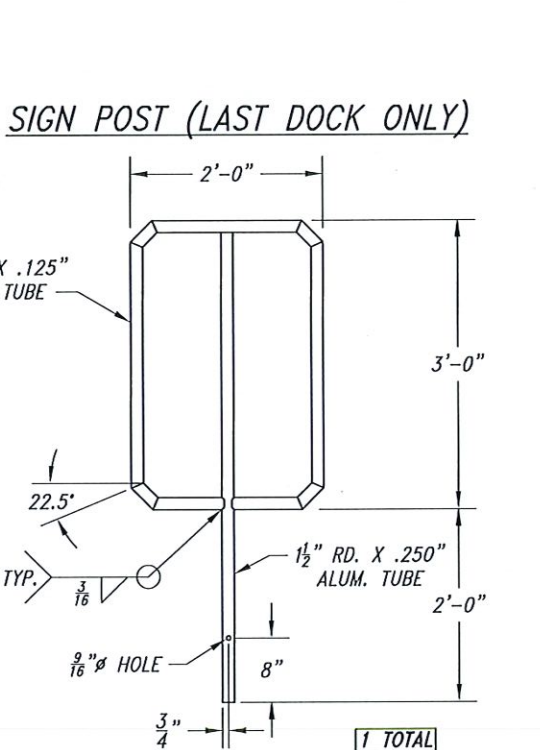
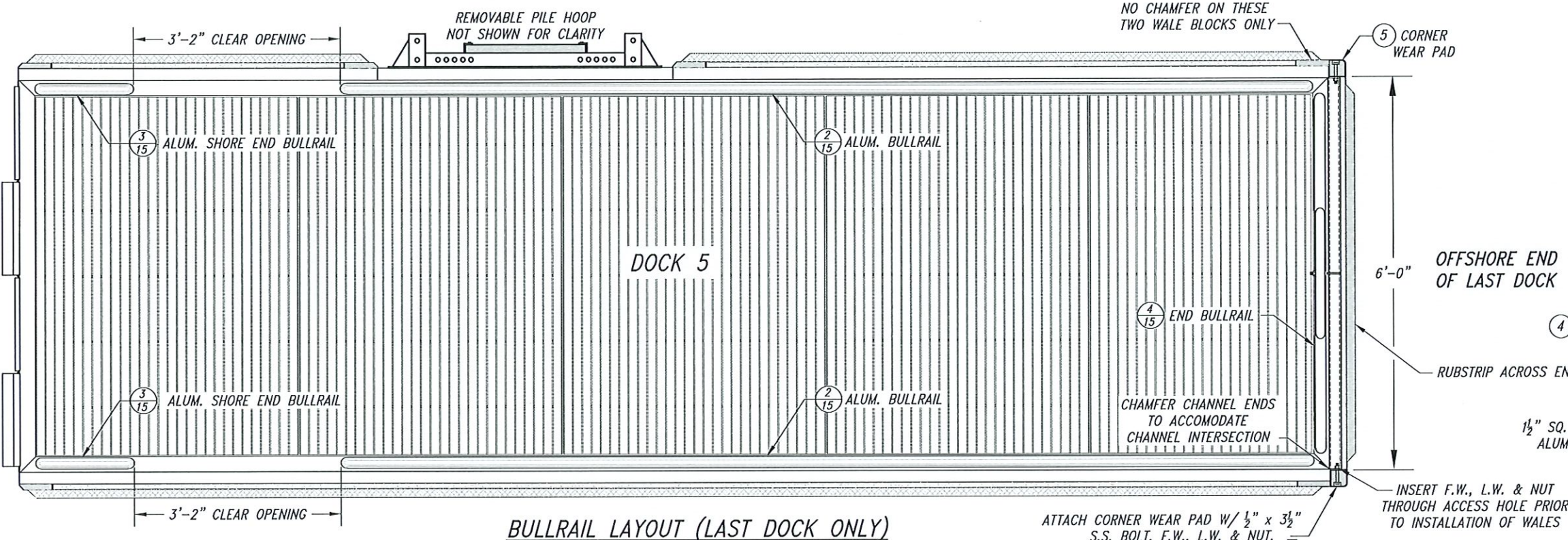
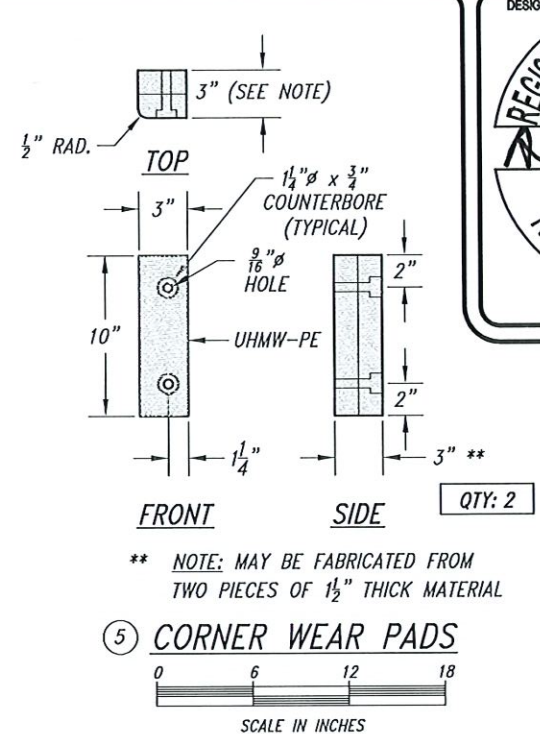
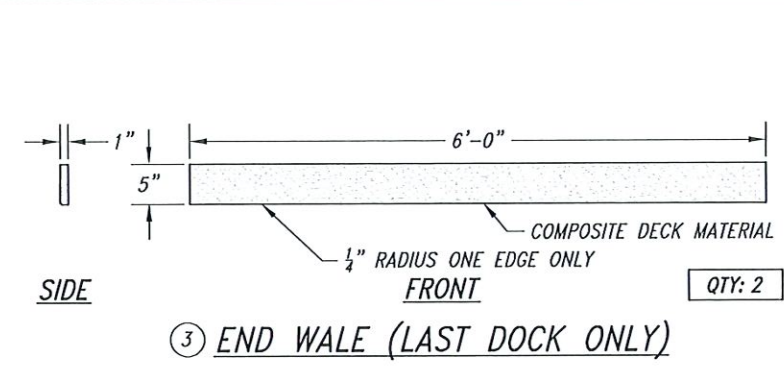
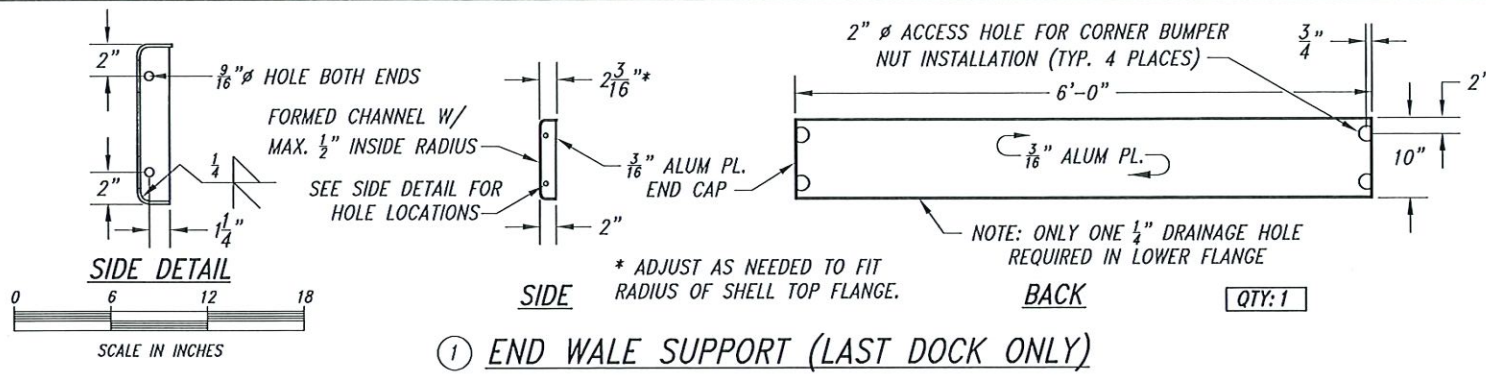

**NOTES:**

- ALL PLATE, FLAT BAR, AND FORMED SHAPES SHALL BE 5086 ALUMINUM ALLOY PER SPECIFICATIONS.
- ALL ROUND TUBE & PIPE SHALL BE 6061 ALUMINUM ALLOY PER SPECIFICATIONS.

**SIGN NOTES:**

- SIGNS PURCHASED FROM OREGON CORRECTIONS ENTERPRISES BY OWNER (SEE SPECIFICATIONS).
- DELIVERED TO VENDOR FOR ATTACHMENT TO SIGN POSTS. ATTACH TO SIGN POST WITH ALUM RIVETS.
- #RB-01 TO BE VISIBLE FROM THE DOCK
- #RB-11 TO BE VISIBLE FROM THE WATER

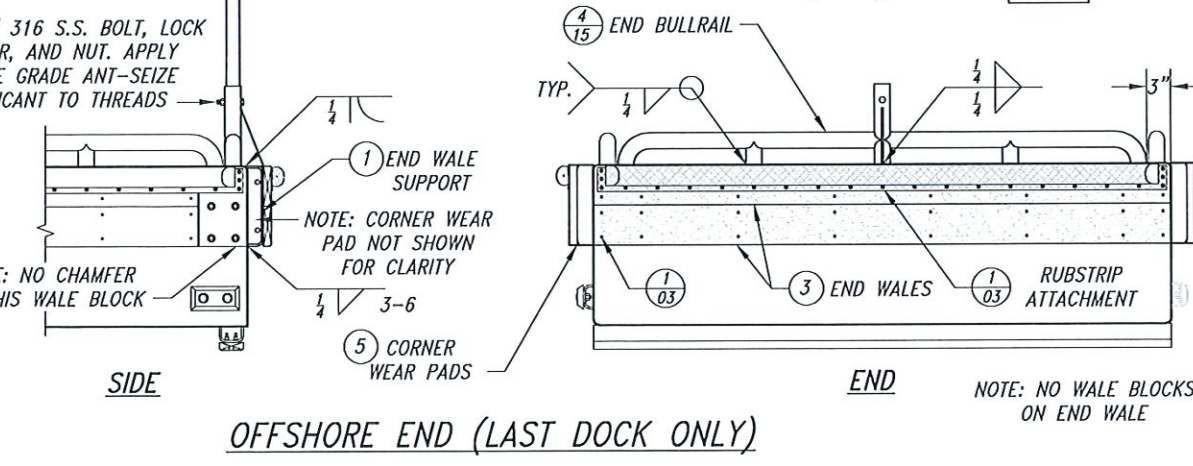
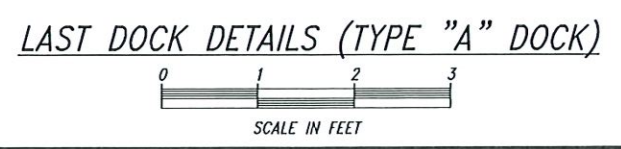

REGISTERED PROFESSIONAL ENGINEER  
 103987PE  
 ALLEN H. CHIOU  
 OREGON  
 NOV. 14, 2023  
 EXPIRES: 12-31-25

FINAL CHECK SIGNATURE  
 ALLEN C.  
 DESIGNER: ALLEN C.  
 DRAFTER: ALLEN C.  
 DATE: 8/15/24

SHEET STATUS  
**FINAL**  
 AS ADVERTISED

OREGON STATE MARINE BOARD

PROJECT LOCATION WATERBODY & FACILITY OWNER  
 COOK PARK RAMP, TUALATIN RIVER - MILE 9.8  
 CITY OF TIGARD

SHEET NUMBER  
**14**

SHEET 14 OF 20  
 DRAWING NO.  
 3403 - 1730 - 14

SHEET DESCRIPTION  
**LAST DOCK DETAILS**

J:\Projects\Cook Park Ramp\1730 - Boarding Dock Replacement\Engineering\Drawings\14.5 - Last Dock End Details (Type A - EPH only).dwg



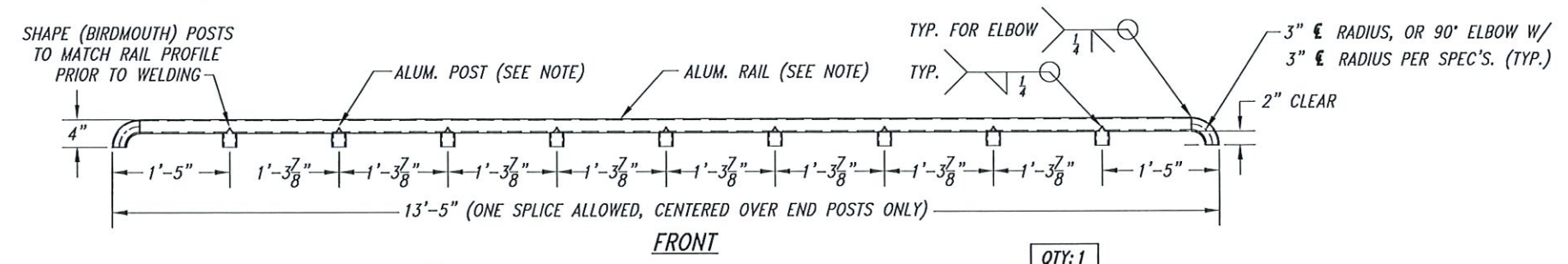

⑤ MODIFIED BULLRAIL (DOCK 4 ONLY) QTY: 1

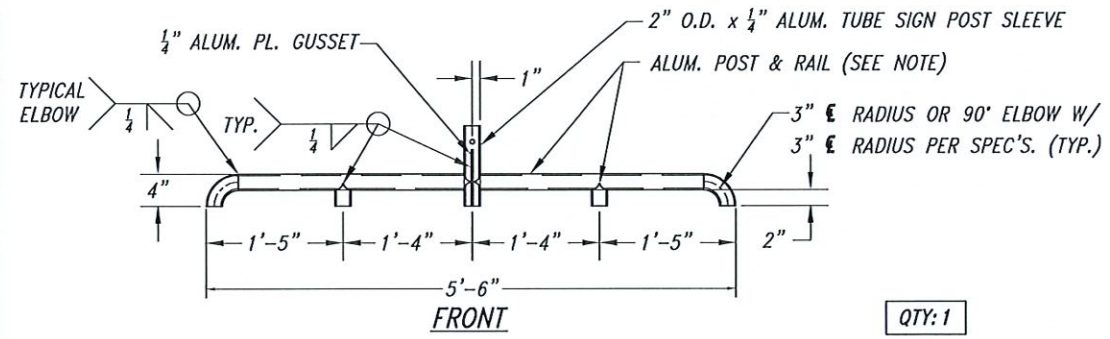

QTY: 1

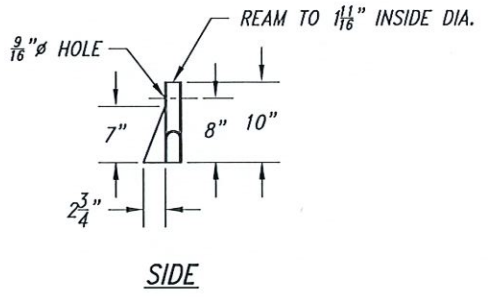

SIDE

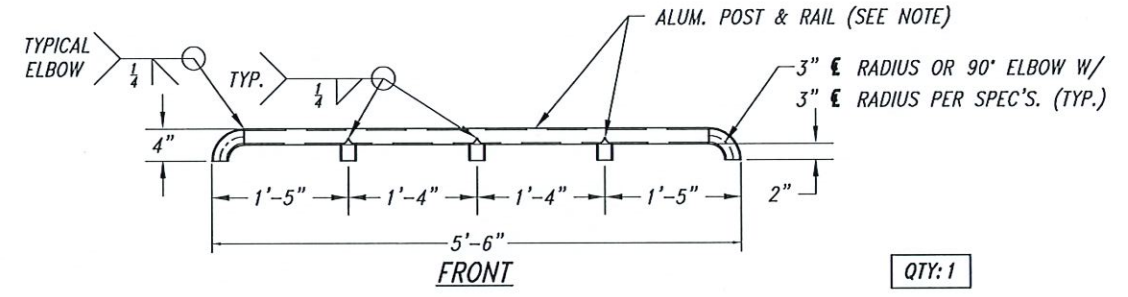

QTY: 1

④ END BULLRAIL (LAST DOCK ONLY)

⑥ END BULLRAIL (DOCK 4 ONLY)

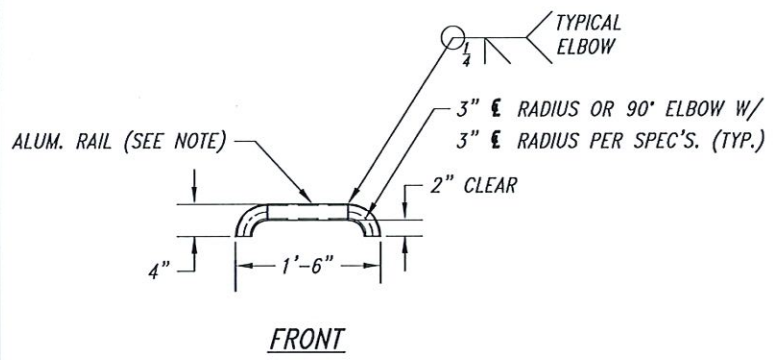

FRONT

③ SHORE-END BULLRAIL (LAST DOCK ONLY) QTY: 2

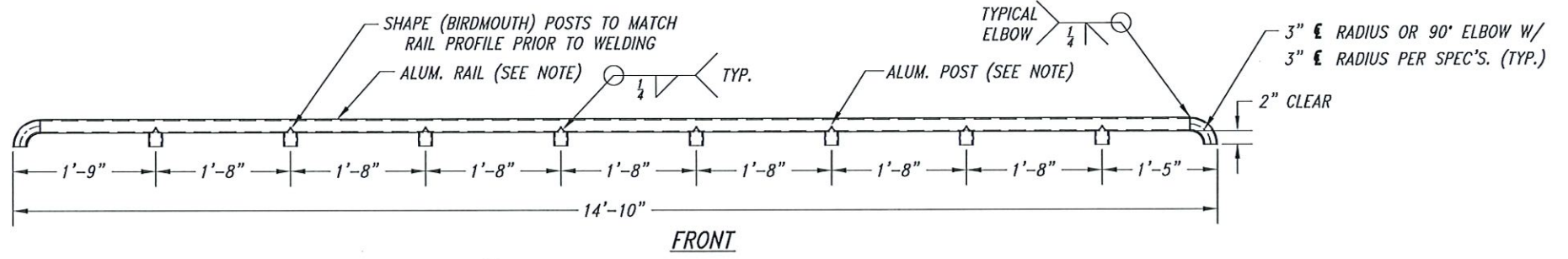

FRONT

② BULLRAIL (LAST DOCK ONLY) QTY: 2

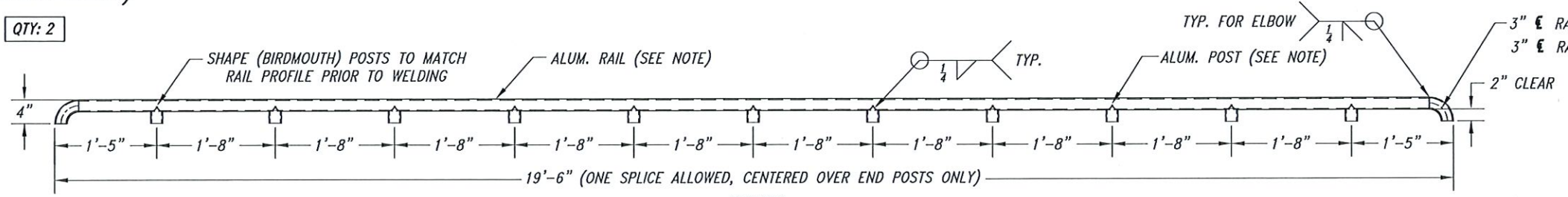

FRONT

① STANDARD BULLRAIL

SEE STANDARD BULLRAIL QUANTITY TABLE

STANDARD BULLRAIL QUANTITY TABLE	
DOCK No.	QTY
D01	2
D02	2
D03	2
D04	1

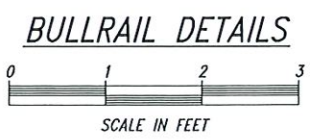

**BULLRAIL NOTE:**  
 ALL BULLRAIL POST & RAILS SHALL BE:  
 • 2" O.D. X 3/16" 6061 ALUM. TUBE  
 OR  
 • 1 1/2" SCH 40 6063 ALUM. PIPE

FINAL CHECK SIGNATURE  
 Allen Chiu

DESIGNER: ALLEN C.  
 DRAFTER: ALLEN C.  
 DATE: 8/15/24

SHEET STATUS  
**FINAL**  
 AS ADVERTISED



PROJECT LOCATION WATERBODY & FACILITY OWNER  
 COOK PARK RAMP, TUALATIN RIVER - MILE 9.8  
 CITY OF TIGARD

SHEET DESCRIPTION  
 BULLRAIL DETAILS

SHEET NUMBER  
**15**

SHEET 15 OF 20  
 DRAWING NO.  
 3403 - 1730 - 15





DESIGNER: ALLEN C.  
 DRAFTER: ALLEN C.  
 DATE: 8/15/24

SHEET STATUS  
**FINAL**  
 AS ADVERTISED



PROJECT LOCATION, WATERBODY & FACILITY OWNER  
**COOK PARK RAMP, TUALATIN RIVER - MILE 9.8**  
 CITY OF TIGARD

SHEET DESCRIPTION  
**STRUCTURAL DETAILS**

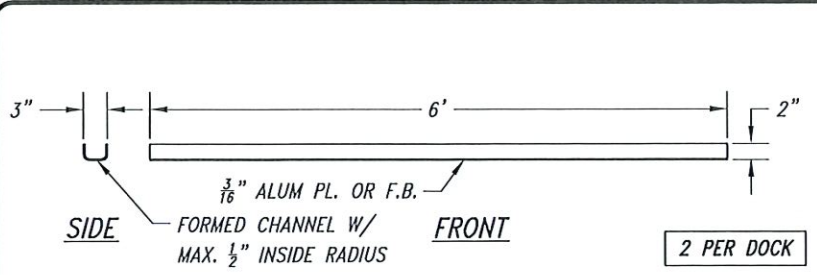

① GROUNDING RAIL SUPPORT

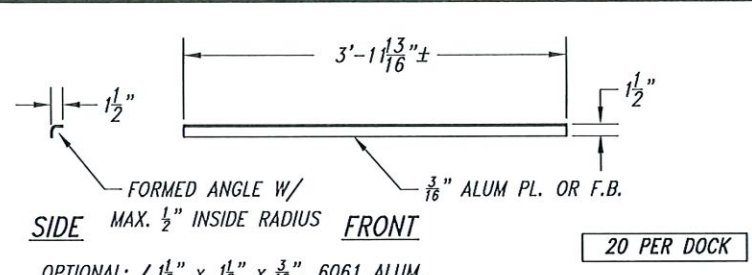

② BOTTOM STIFFENER

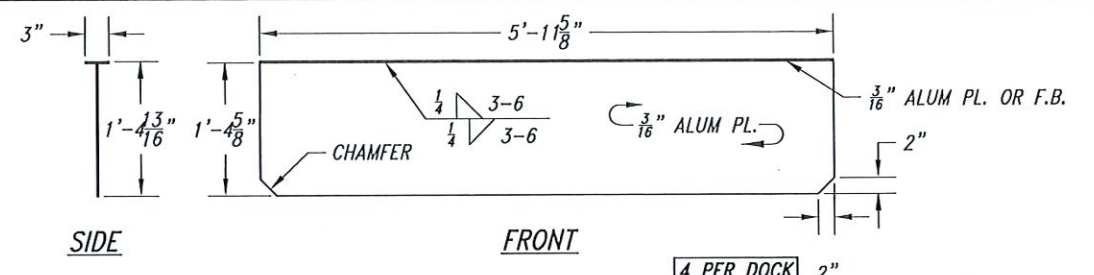

③ BULKHEAD

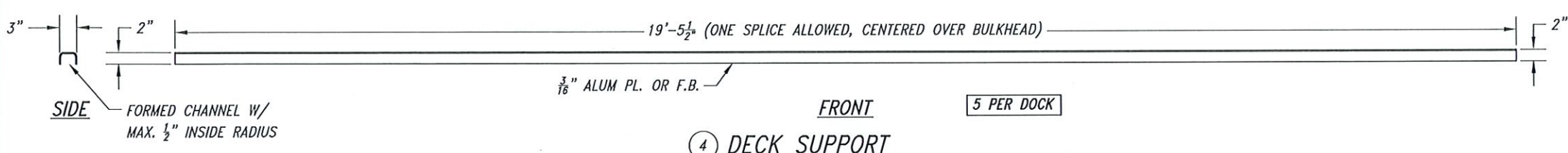

④ DECK SUPPORT

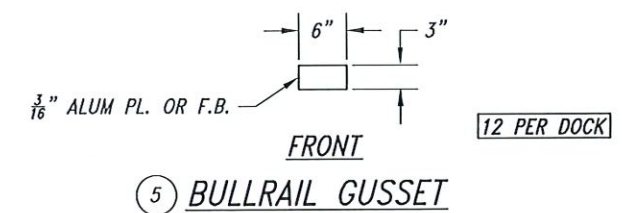

⑤ BULLRAIL GUSSET

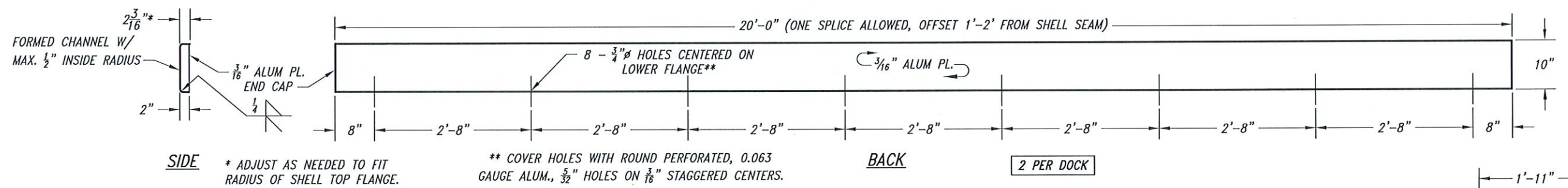

⑥ WALE SUPPORT

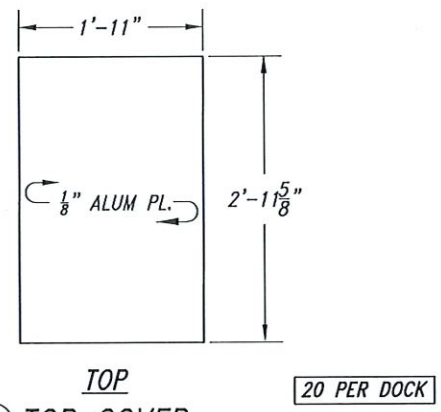

⑩ TOP COVER

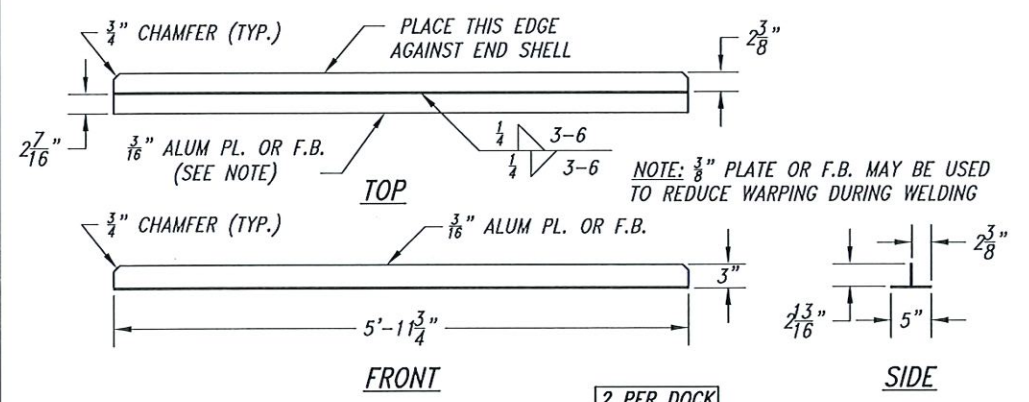

⑧ END STIFFENER

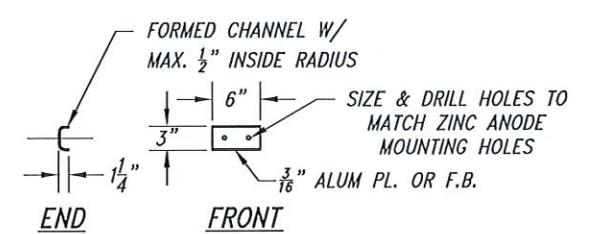

⑨ ANODE BRACKET

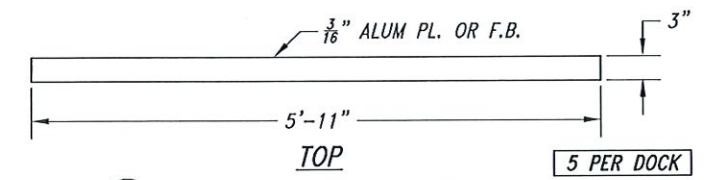

⑪ TOP COVER SPACER

**NOTES:**  
 1. ALL PLATE, FLAT BAR, AND FORMED SHAPES SHALL BE 5086 ALUMINUM ALLOY PER SPECIFICATIONS.  
 2. ALL ROUND TUBE SHALL BE 6061 ALUMINUM ALLOY PER SPECIFICATIONS.

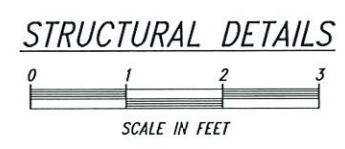

J:\Projects\Cook Park Ramp\1730 - Boarding Dock Replacement\Engineering\Drawings\16.3 - Structural Details (Type A - EPH Only).dwg



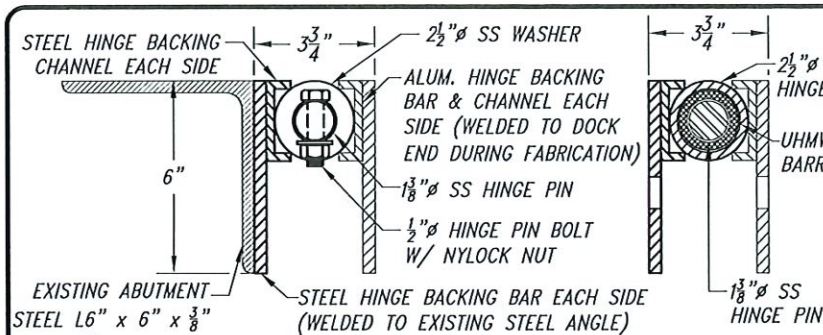

① HINGE BARREL ASSEMBLY & SECTION

- NOTES:**
1. ALL PLATE, FLAT BAR, TUBE, & SHAPES ON ABUTMENT SIDE SHALL BE A36 MILD STEEL. HOT DIP GALVANIZE AFTER FABRICATION.
  2. ALL PLATE, FLAT BAR, TUBE, & SHAPES ON DOCK 1'S SHORE END SHALL BE ALUMINUM.
  3. REMOVE EXISTING ABUTMENT CONNECTION (BARRELS, PLATES, ETC.) FROM THE EXISTING ABUTMENT STEEL ANGLE & FIELD WELD NEW ABUTMENT HINGE CONNECTION TO THE EXISTING ABUTMENT STEEL ANGLE.
  4. ENSURE A SANDBLAST FINISH TO ALL WALKING SURFACES.
  5. LEFT & RIGHT SIDES ARE DETERMINED WHEN A PERSON IS FACING DOWNHILL OF THE RAMP.

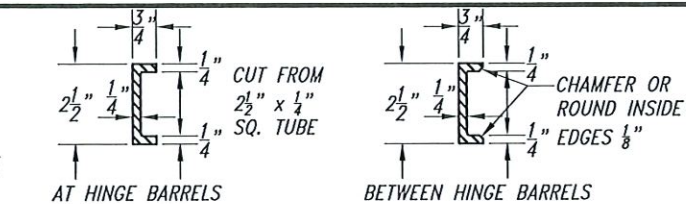

② HINGE BACKING CHANNEL SECTIONS (TYP.)

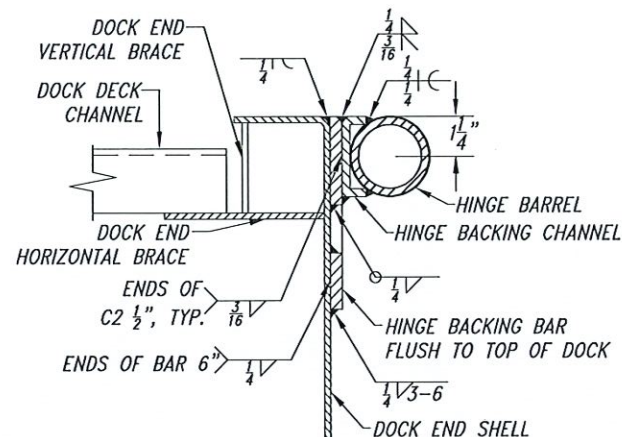

④ DOCK 1 END SECTION

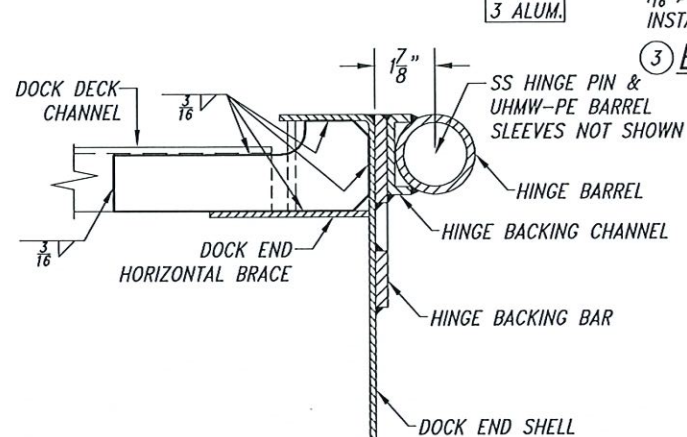

⑤ DOCK 1 SECTION AT HINGE END GUSSET

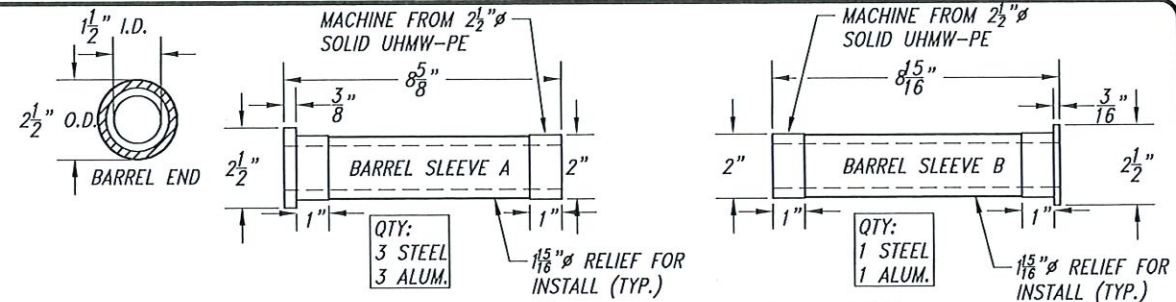

③ BARREL SLEEVE DETAILS

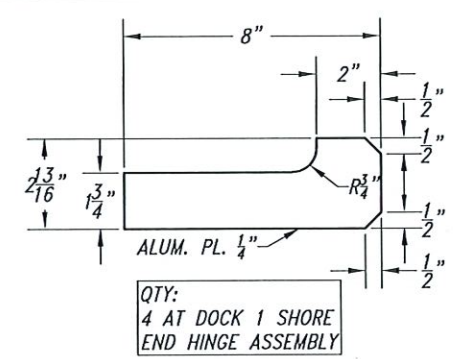

⑥ HINGE END GUSSET

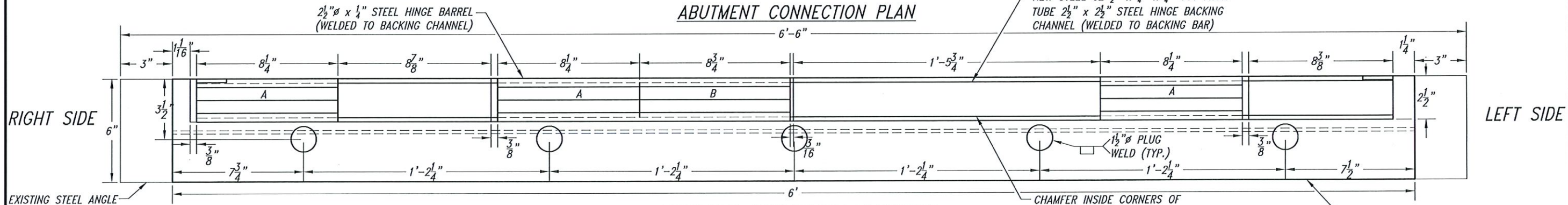
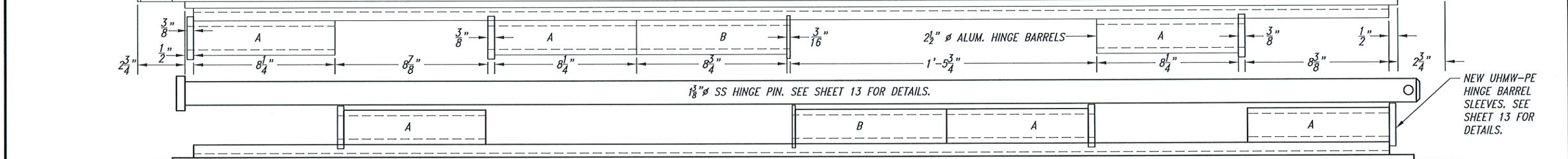
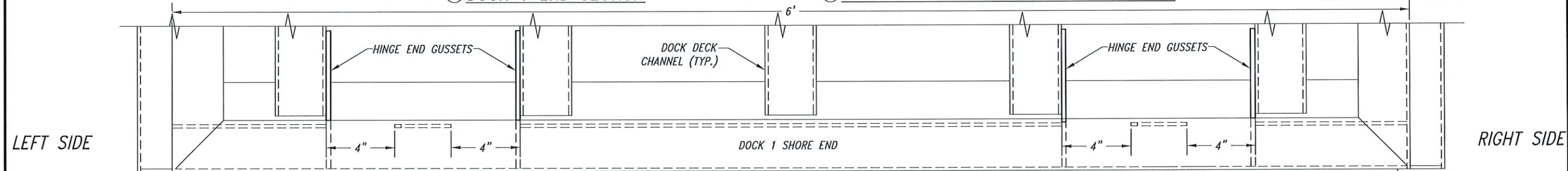

ABUTMENT HINGE DETAILS



DESIGN ENGINEER  
**REGISTERED PROFESSIONAL ENGINEER**  
 103987PE  
*Allen H. Chiu*  
 OREGON  
 NOV. 14, 2023  
**ALLEN H. CHIU**  
 EXPIRES: 12-31-25

FINAL CHECK SIGNATURE  
*Allen H. Chiu*

DESIGNER: ALLEN C.  
 DRAFTER: ALLEN C.  
 DATE: 8/15/24

SHEET STATUS  
**FINAL**  
 AS ADVERTISED



PROJECT LOCATION: WATERBODY & FACILITY OWNER:  
**COOK PARK RAMP, TUALATIN RIVER - MILE 9.8**  
**CITY OF TIGARD**  
 SHEET DESCRIPTION:  
**ABUTMENT HINGE DETAILS**  
 SHEET NUMBER:  
**17**  
 SHEET 17 OF 20  
 DRAWING NO.  
 3403 - 1730 - 17

J:\Projects\Cook Park Ramp\1730 - Boarding Dock Replacement\Engineering\Drawings\17.3 - Abutment Hinge Details.dwg





FINAL CHECK SIGNATURE  
*Allen H. Chiou*

DESIGNER: ALLEN C.  
DRAFTER: ALLEN C.  
DATE: 8/15/24

SHEET STATUS  
**FINAL**  
AS ADVERTISED



PROJECT LOCATION, WATERBODY & FACILITY OWNER:  
**COOK PARK RAMP, TUALATIN RIVER - MILE 9.8**  
CITY OF TIGARD

SHEET DESCRIPTION:  
**FIBERGLASS DECK PANEL DETAILS**

SHEET NUMBER  
**18**

SHEET 18 OF 20  
DRAWING NO.  
3403 - 1730 - 18

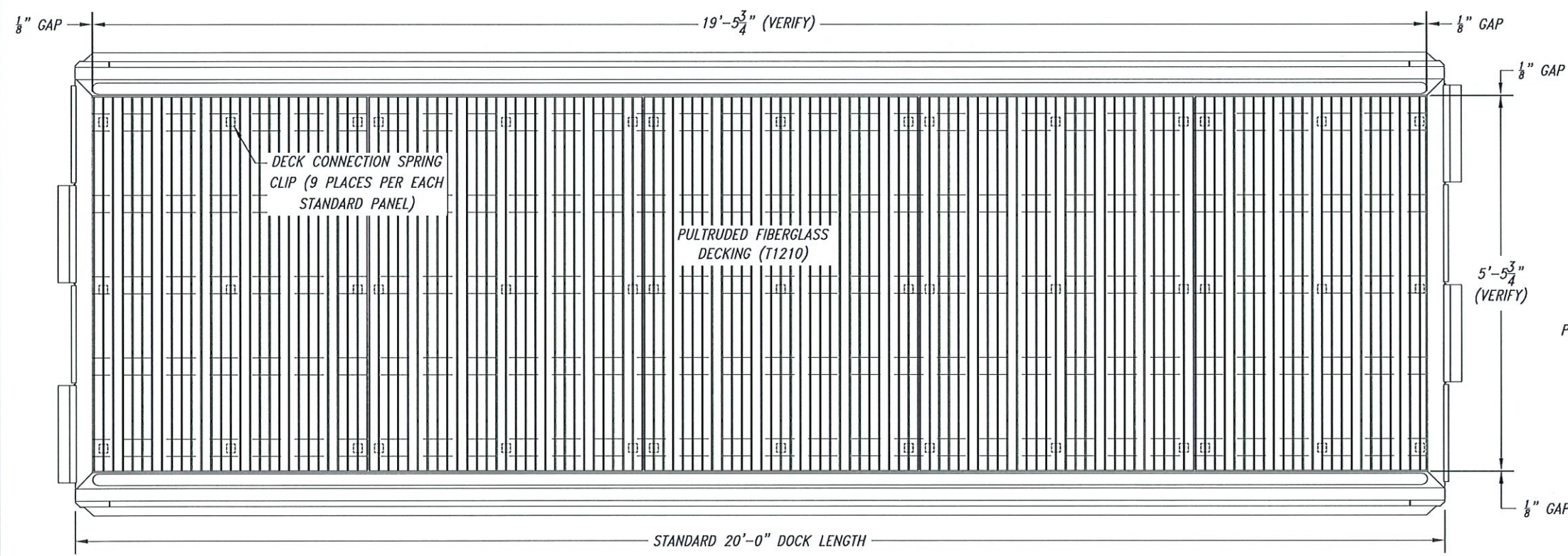

PULTRUDED FIBERGLASS DECKING LAYOUT

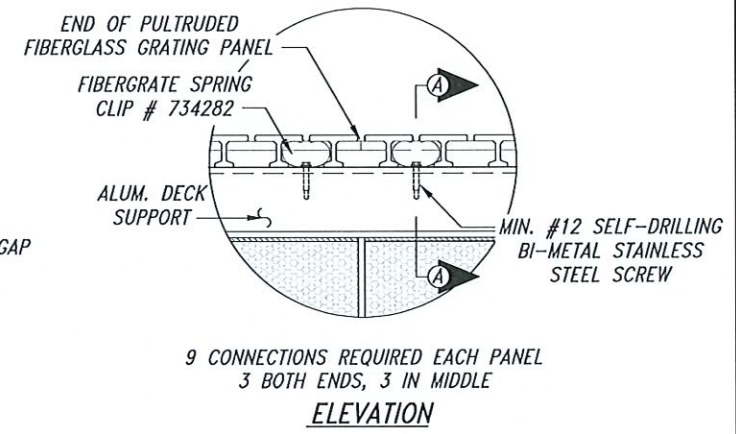
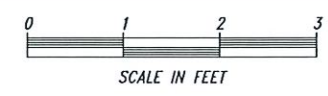

9 CONNECTIONS REQUIRED EACH PANEL  
3 BOTH ENDS, 3 IN MIDDLE  
ELEVATION

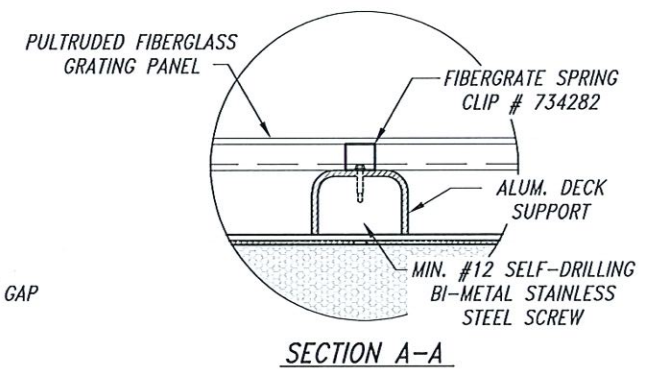

SECTION A-A

DECKING CONNECTION DETAILS

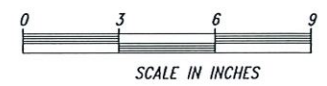



REFERENCE STANDARD ALUMINUM DOCK DETAILS (SHEET 03) FOR CONSTRUCTION. MODIFY AS SHOWN ON THIS PAGE.

DESIGN ENGINEER  
**REGISTERED PROFESSIONAL ENGINEER**  
 103987PE  
*Allen H. Chiu*  
 OREGON  
 NOV. 14, 2023  
**ALLEN H. CHIU**  
 EXPIRES: 12-31-25

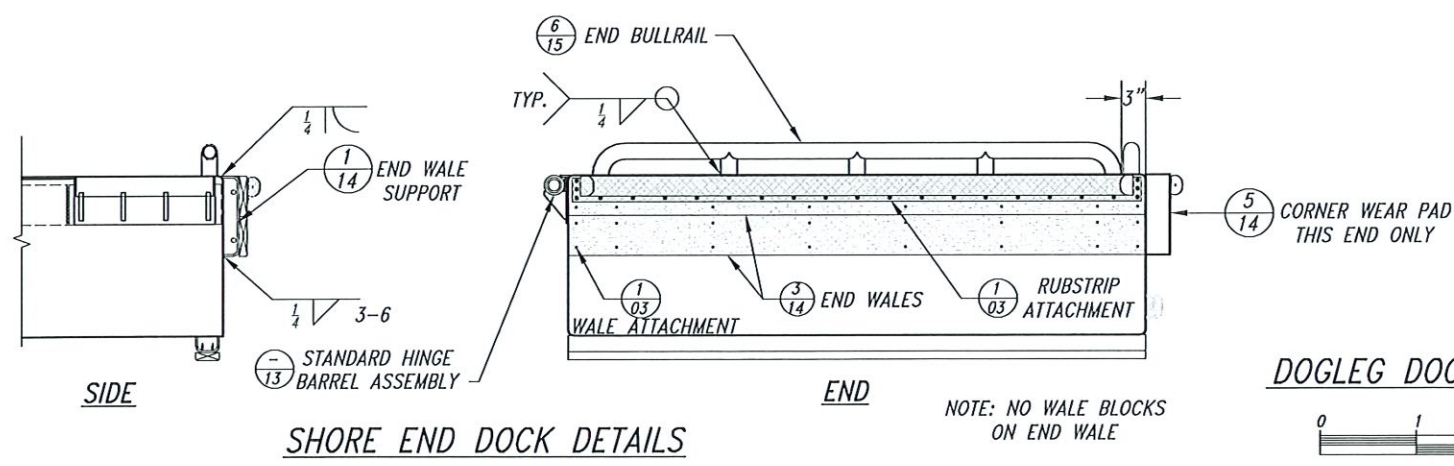
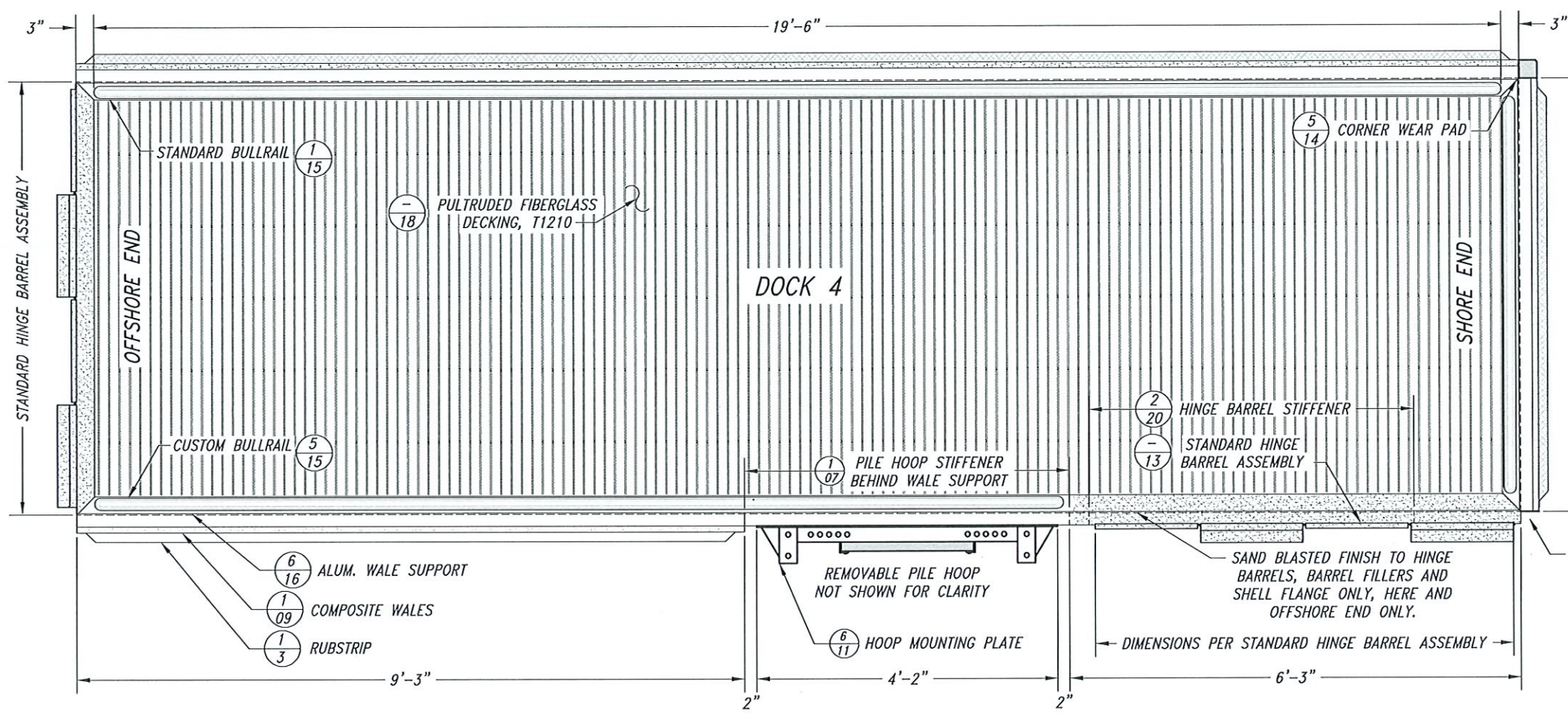
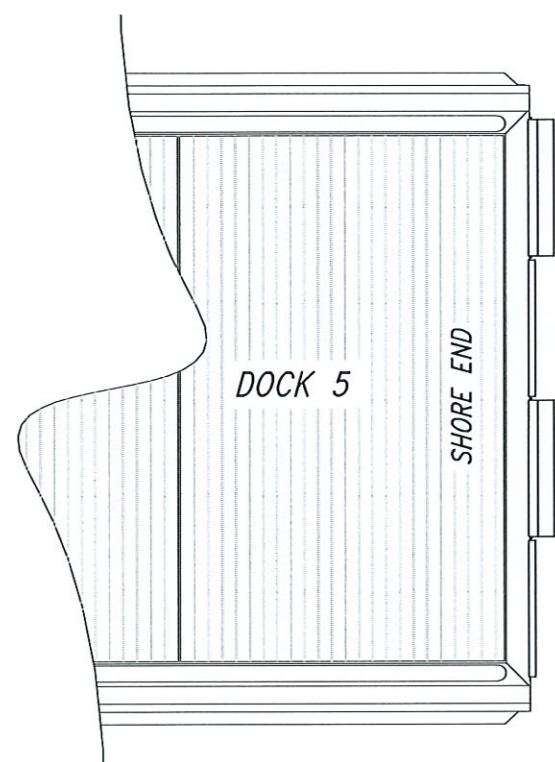
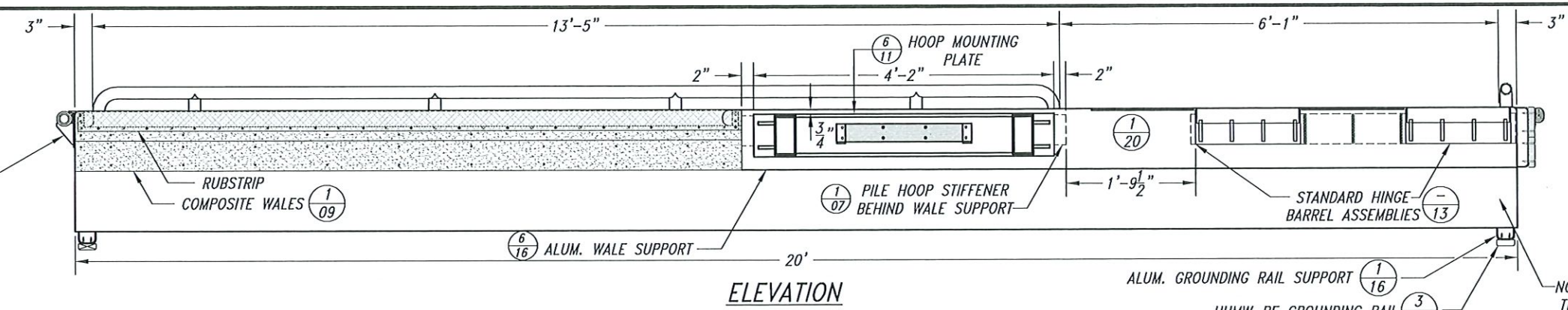

**DOGLEG DOCK (TYPE "A")**

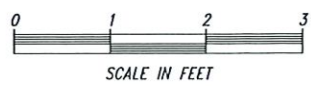

FINAL CHECK SIGNATURE  
*Allen H. Chiu*  
 DESIGNER: ALLEN C.  
 DRAFTER: ALLEN C.  
 DATE: 8/15/24

SHEET STATUS  
**FINAL**  
 AS ADVERTISED



PROJECT LOCATION, WATERBODY & FACILITY OWNER  
**COOK PARK RAMP, TUALATIN RIVER - MILE 9.8**  
**CITY OF TIGARD**  
 SHEET DESCRIPTION  
**DOGLEG DOCK (TYPE "A")**

SHEET NUMBER  
**19**  
 SHEET 19 OF 20  
 DRAWING NO.  
 3403 - 1730 - 19



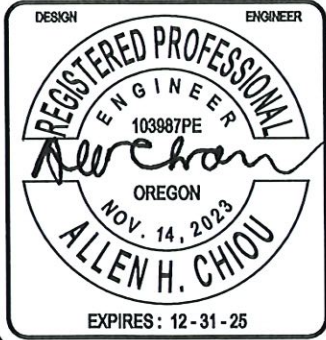

DESIGNER: ALLEN C.  
 DRAFTER: ALLEN C.  
 DATE: 8/15/24

SHEET STATUS  
**FINAL**  
 AS ADVERTISED



PROJECT LOCATION, WATERBODY & FACILITY OWNER:  
**COOK PARK RAMP, TUALATIN RIVER - MILE 9.8**  
**CITY OF TIGARD**

SHEET DESCRIPTION:  
**HINGE BARREL STIFFENER (DOGLEG DOCK)**

SHEET NUMBER  
**20**

SHEET 20 OF 20  
 DRAWING NO.  
 3403 - 1730 - 20

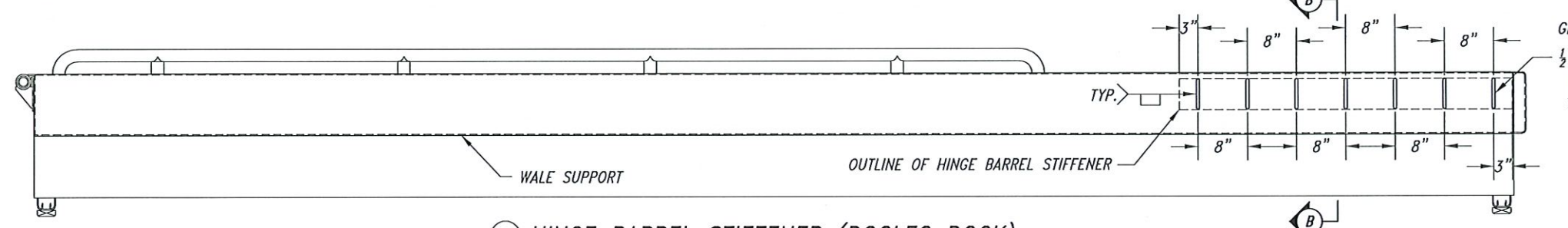
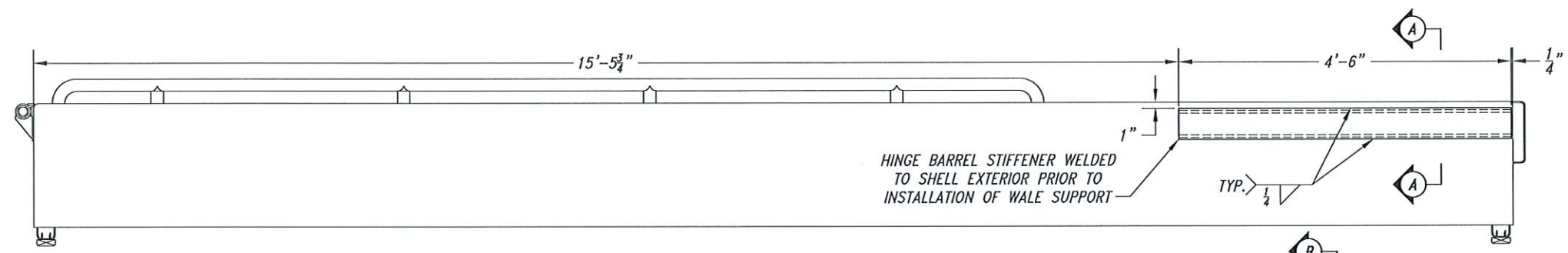

① HINGE BARREL STIFFENER (DOGLEG DOCK)

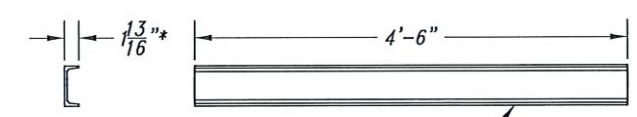
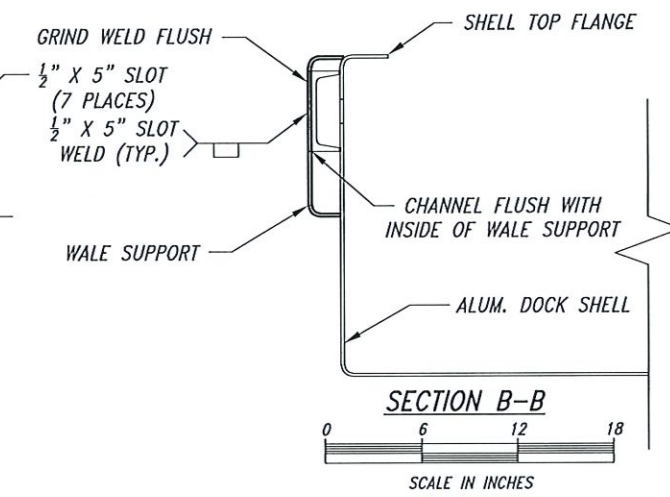
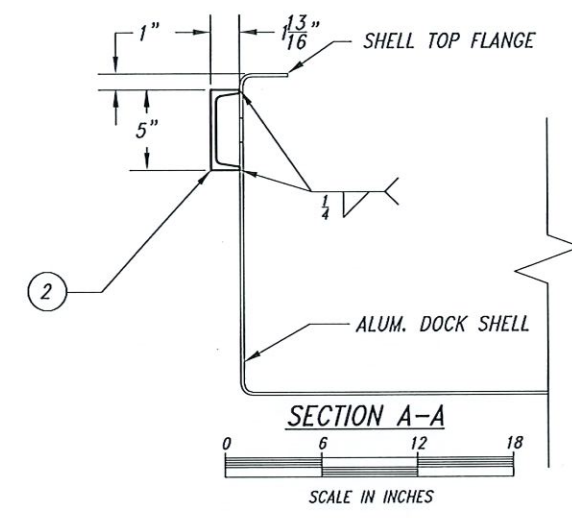

② HINGE BARREL STIFFENER  
 \* TRIM FLANGES 1/16"± TO ALLOW CHANNEL WEB TO SET FLUSH WITH INSIDE OF WALE SUPPORT

0 1 2 3

SCALE IN FEET

J:\Projects\Cook Park Ramp\Boarding Dock Replacement\Engineering\Drawings\20 - Hinge Barrel Stiffener (Dogleg Dock).dwg